



# BPMN Choreography

Barbara Re

# Choreography Diagram

Focuses on the **interactions** among two or more participants.

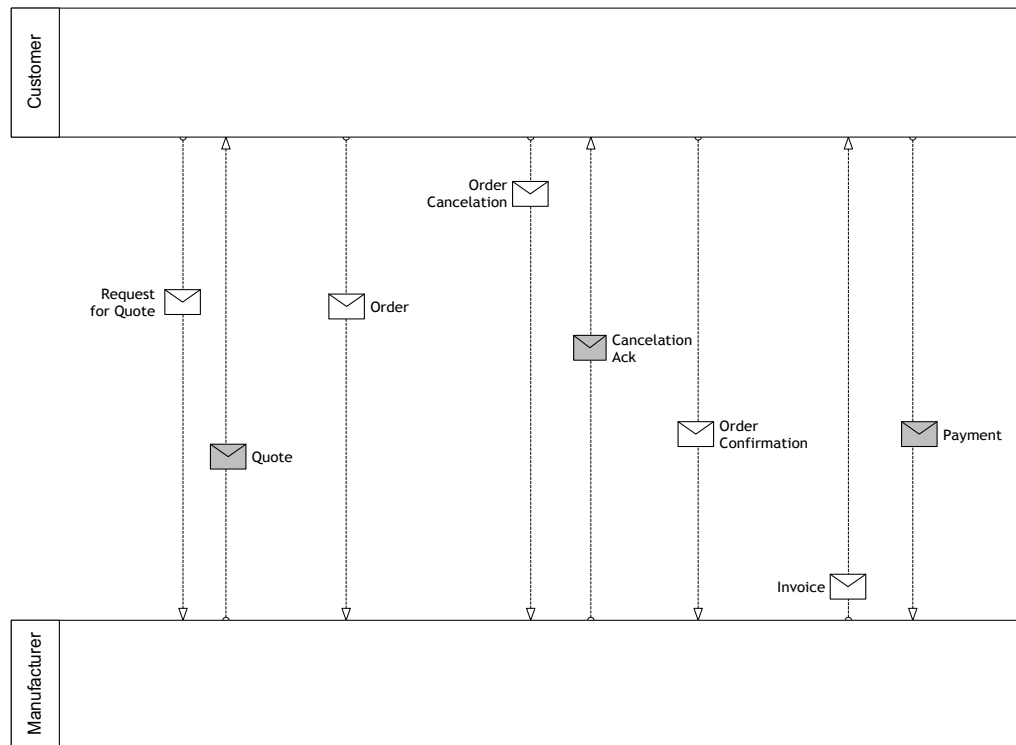

# Choreography Diagram (cont'ed)

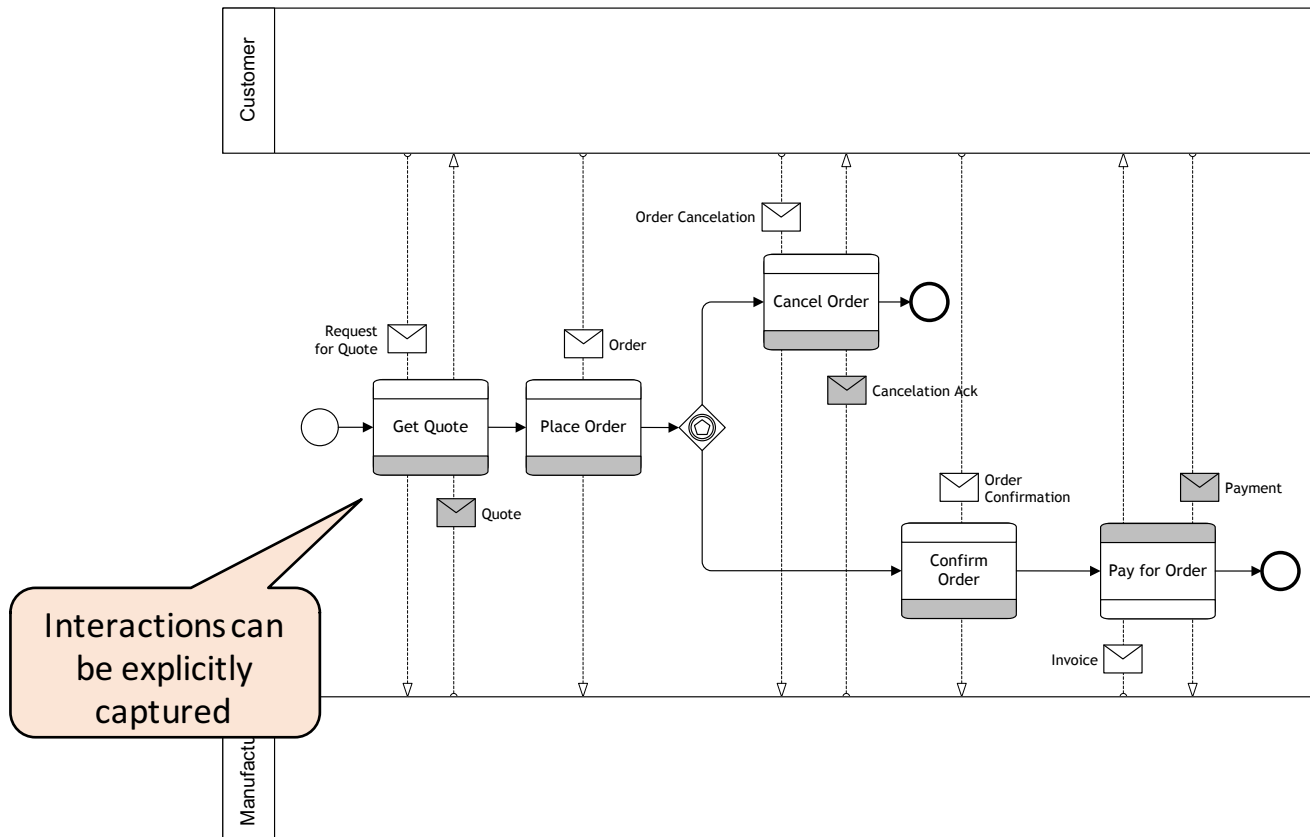

# Choreography Diagram (cont'ed)

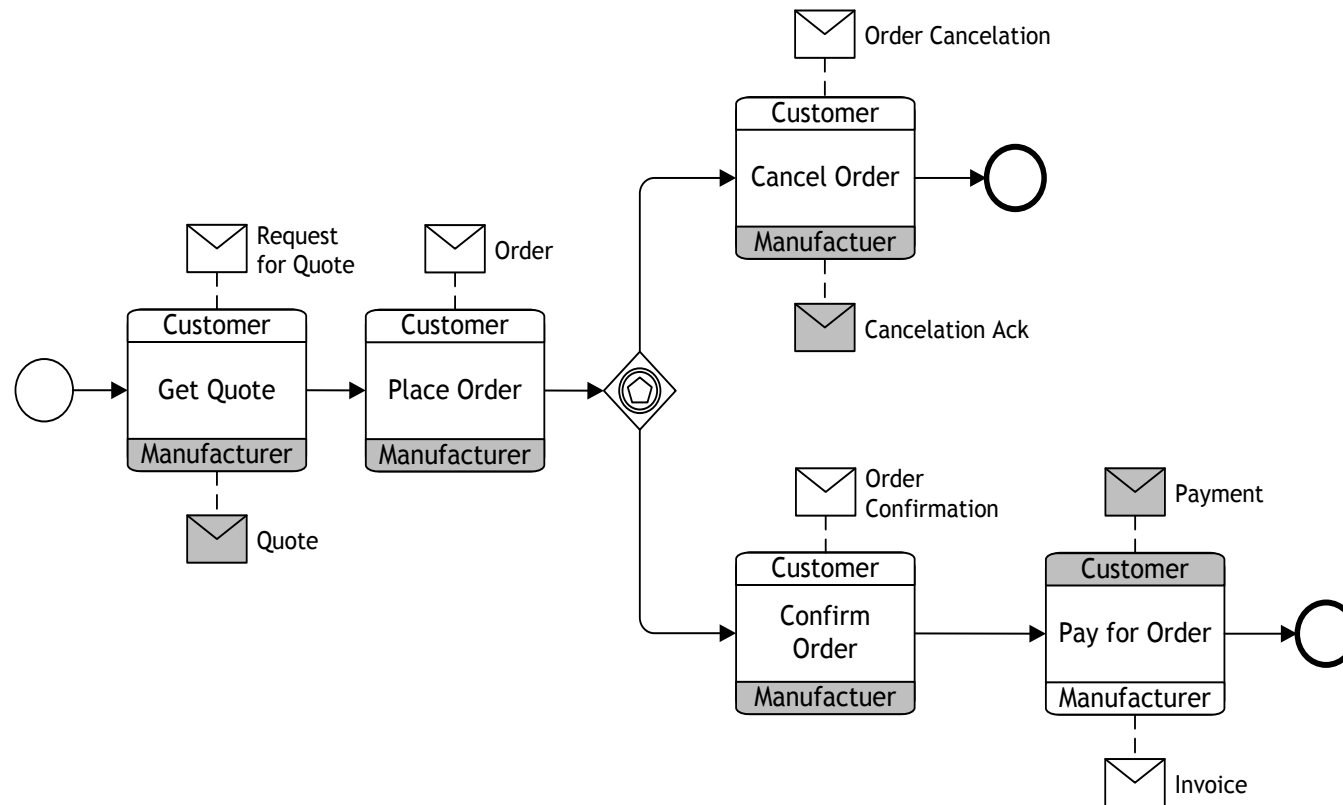

# Choreography Task

- Atomic activity
- Represents an interaction between two business parties
- Either one-way (asynchronous) or two-way (synchronous)
- Distinction between initiating and receiving party

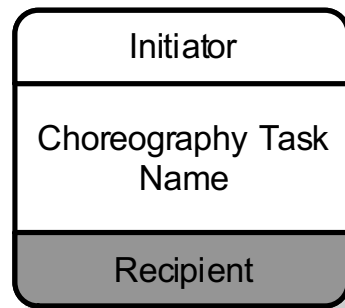

# Choreography Task

- Band of initiating party unfilled
- Message icons optional

Choreography Task

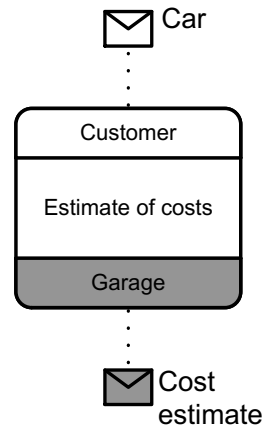

Collaboration View

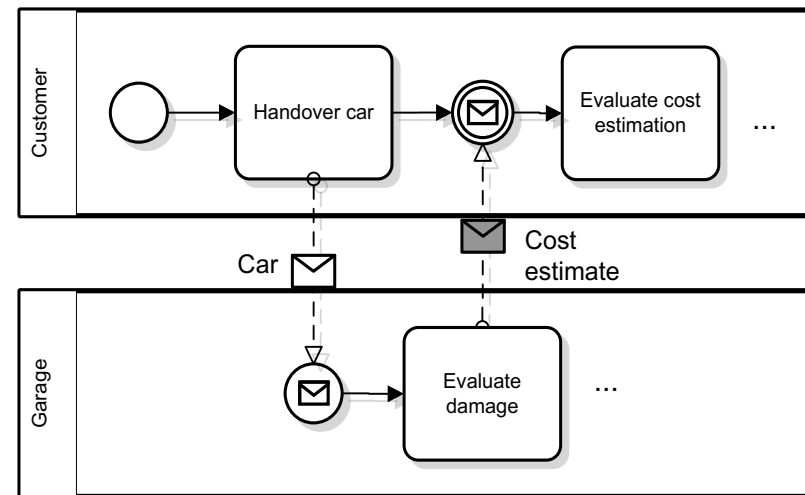

# Basic Choreography Elements

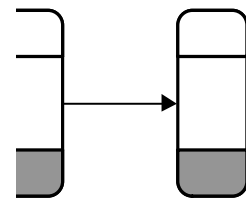

Sequence flow – Connects and orders choreography tasks, events and gateways



Events – Most process events allowed. No non-interrupting events



Gateways – All process gateways allowed: Exclusive, Inclusive, Parallel and Event-based gateways

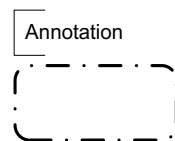

Text annotations, groups – No restrictions on their use

# Choreography Sequencing Constraints

The initiator of a Choreography Activity must have been involved in the previous Activity (excluding first activity)

*Why?!*

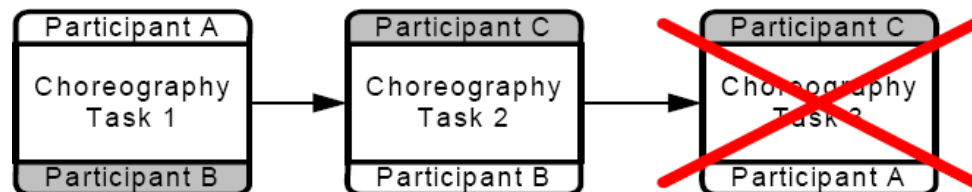



# Choreography Sequencing Constraints

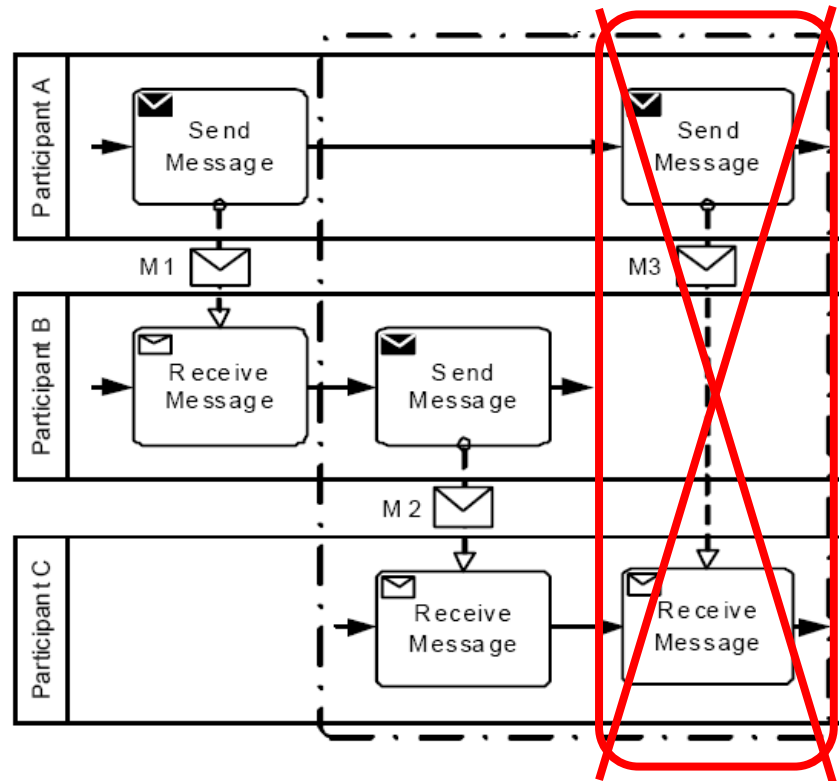

# Example: Choreography of an auction

A Seller sends information about an item he wants to sell to an auction Provider. The Provider publishes the auction by offering the item to the Bidder. Once the auction has started the Bidder places an offer. In case the item is sold the auction Provider finalises the purchase with the Buyer, otherwise he notifies the Seller that his item has not been sold.

# Solution: Choreography of an auction

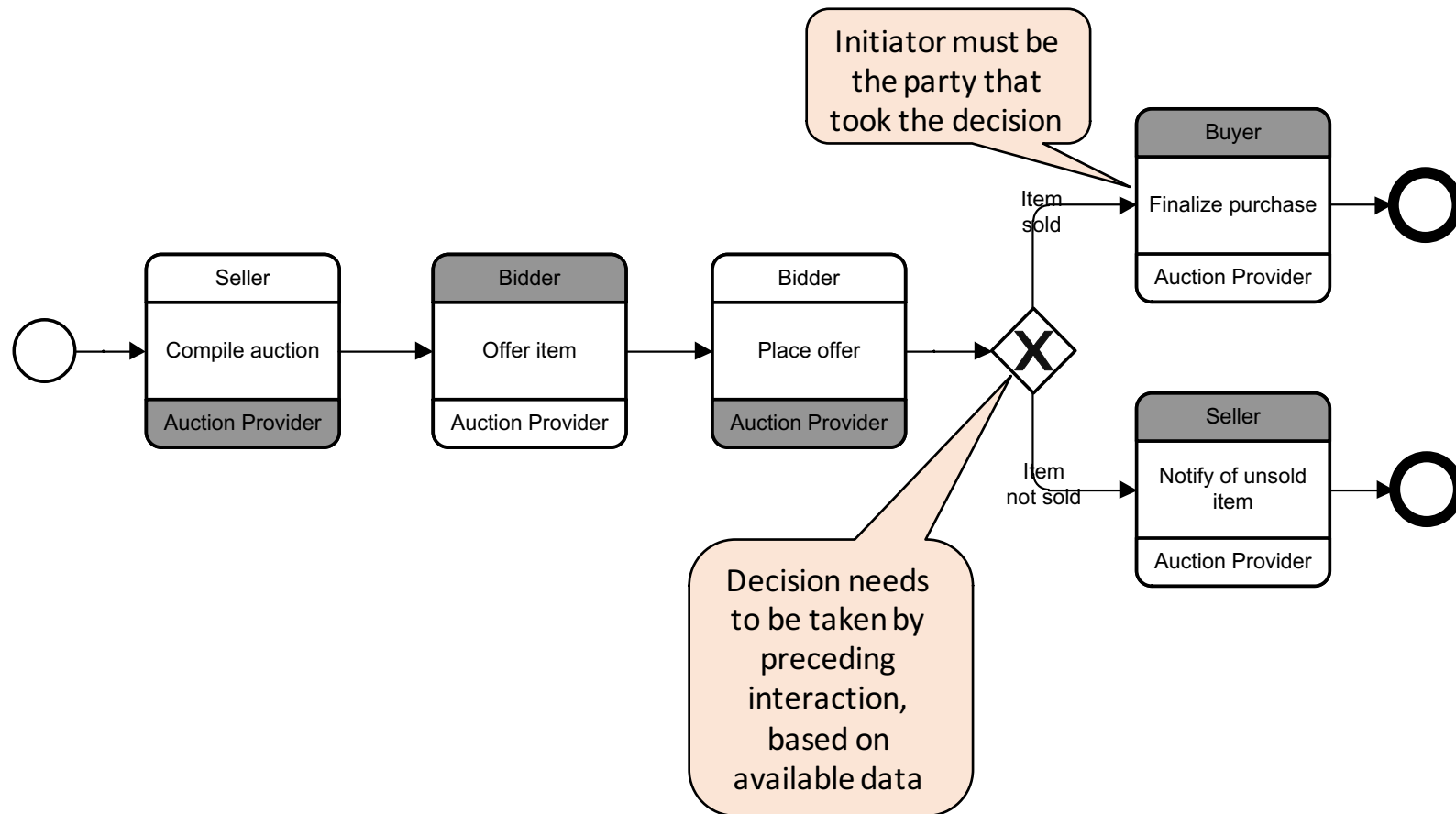

# Choreography Task – Internal Markers

Only one of the loop or multi-instance applicable

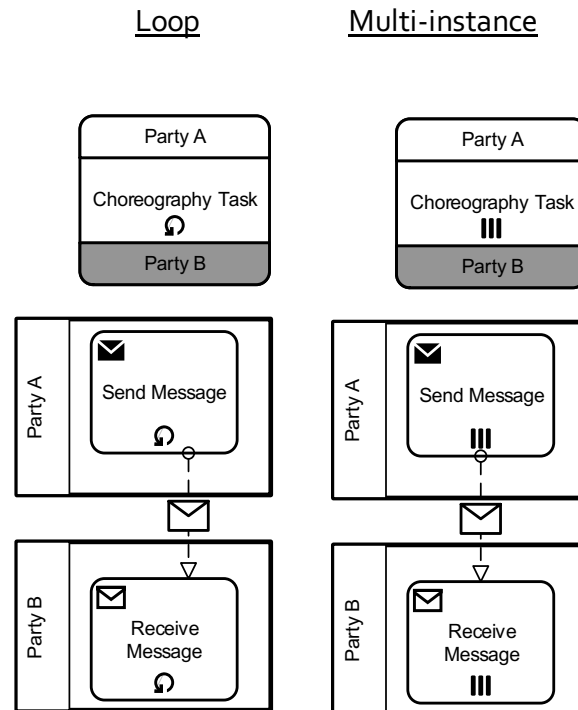

# Choreography Task

## Multi-instance Party marker

- Parties may be multi-instance
- E.g. customers or shippers

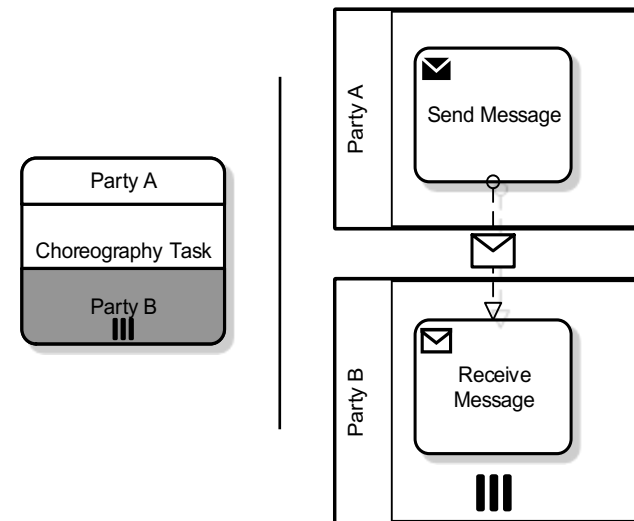

# Example: Choreography of an auction

Where can we use the MI party in the auction example?

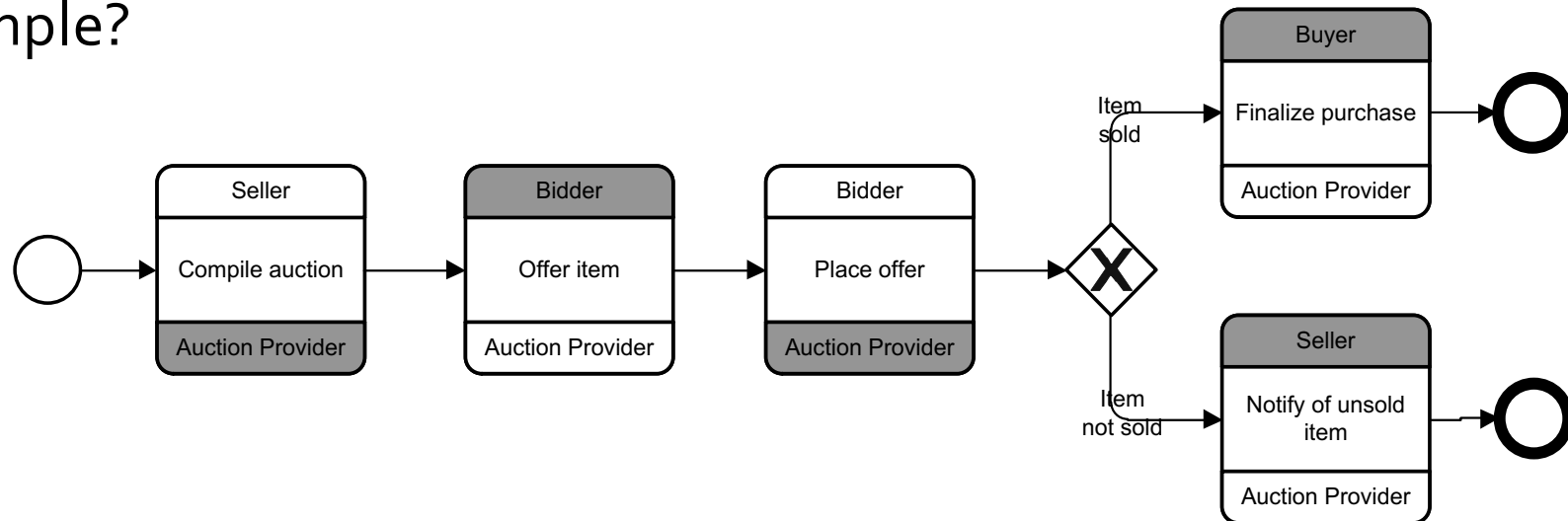

# Example: Choreography of an auction

Where can we use the MI party in the auction example?

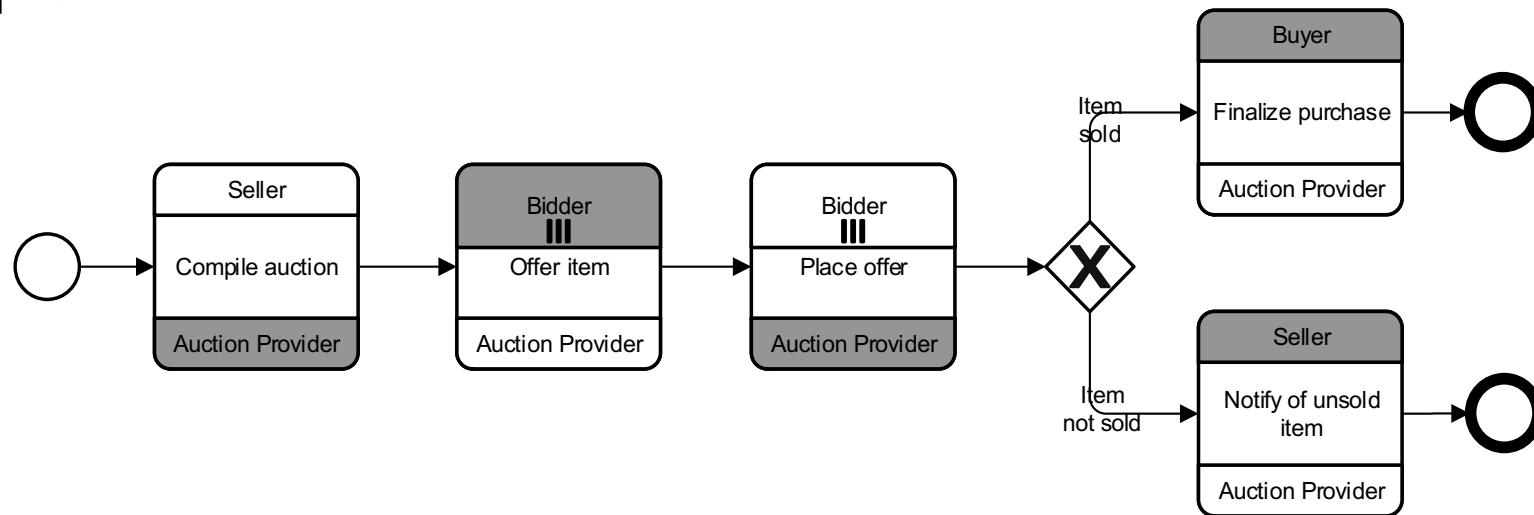

# Sub-Choreography

- Compound activity of a choreography
- Involves at least two business parties
- Loop, MI activity and MI party markers are applicable

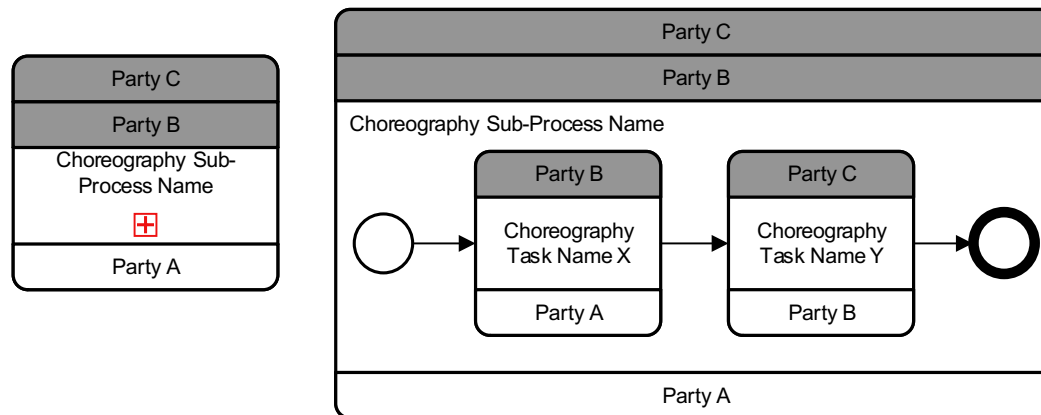



# Example: Choreography

Use this diagram as a template to build the corresponding collaboration diagram

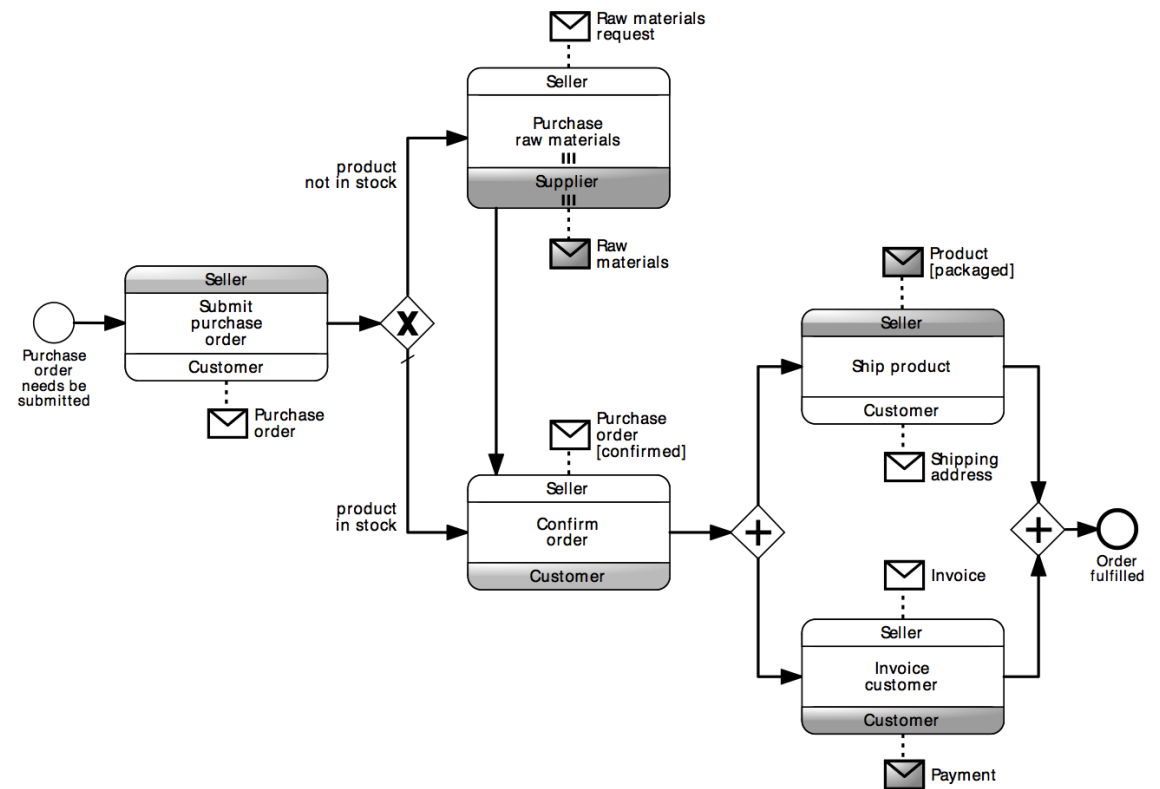

# Solution

