



BPMN

Enterprise and Business Process Modelling

Barbara Re

Outline

- Motivations and Definition
- Business Process Life-Cycle
- Classification of Business Process

BPMN

- Business Process ~~Modelling~~ **Model and** Notation = BPMN
- The primary goal of BPMN is to provide a notation that is readily understandable by all business users:
 - the business analysts that create the initial drafts of the process,
 - the technical developers responsible for implementing the technology that will perform those process
 - the business people who will manage and monitor those processes
- Thus, BPMN creates a standardized bridge for the gap between the business process design and process implementation
- We focus on it since it is the de facto standard notation to model BPs in particular within industrial contexts

History

The vendors realized immediately there was a need of a graphical representation for the language oriented towards the needs of business users. Not a notation that directly represents the precise execution language under development.

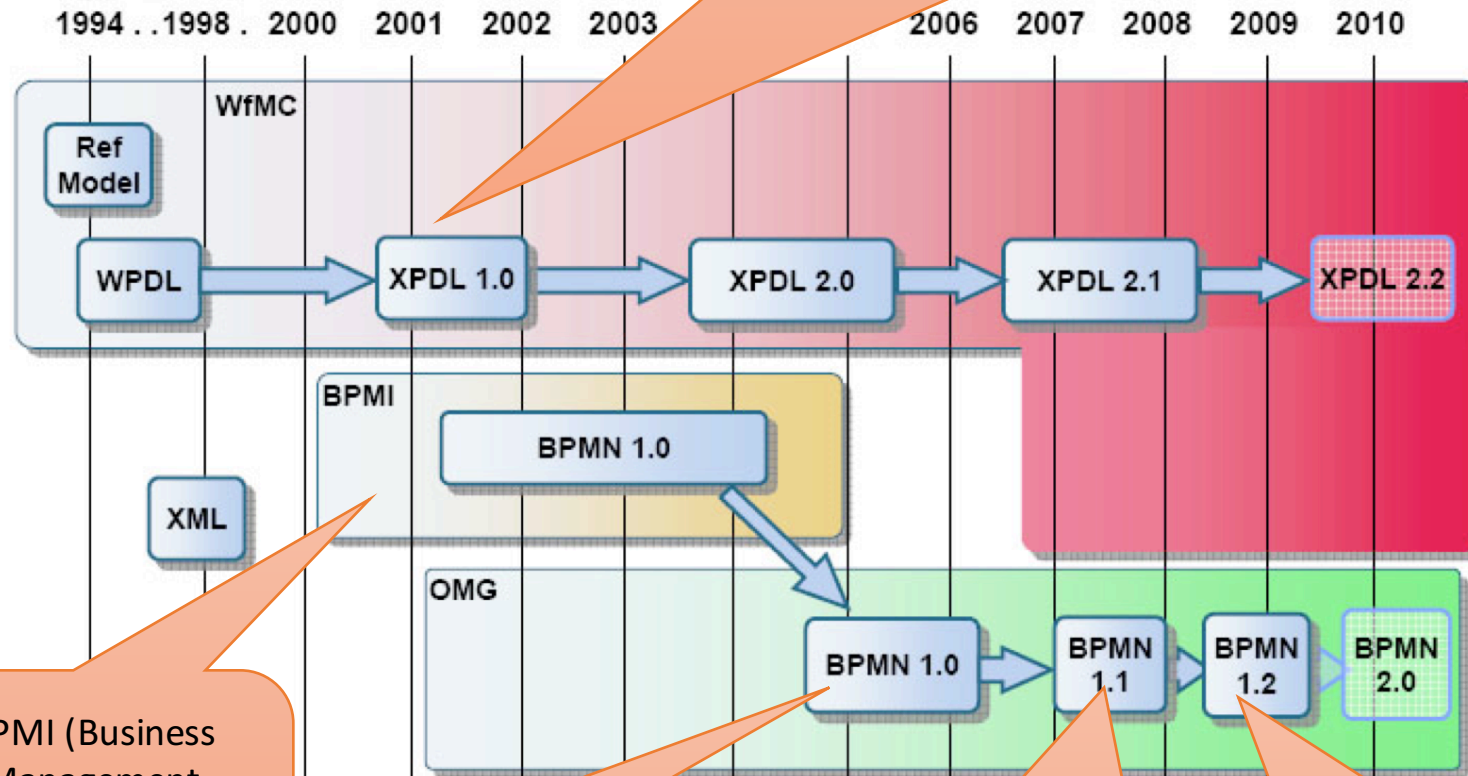

In 2001 BPMI (Business Process Management Initiative) developed BPML as an XML process execution language.

In 2004 **BPMN 1.0** was released to the public and **in 2006 it was adopted as OMG standard.**

In Feb.2008 **BPMN 1.1** was released to the public, **making the meaning of the notation more explicit.**

BPMN 1.2 does not include any significant graphical changes; **modifications were merely editorial.**

BPMN 1.2 vs BPMN 2.0

- **BPMN 1.2** provides a mapping from a “valid” BPMN diagram to BPEL, such that an engine can execute the process
 - The 1.2 specification provides only **contained verbal descriptions** of the graphic notations elements and modeling rules, this leads to misleading and confusions in the translation process
- **BPMN 2.0 beta 2** was introduced in June 2010
 - It represents the biggest revision of BPMN since its inception
- BPMN 2.0 received a **formal definition** in the form of a **meta-model**, that is a precise definition of the constructs and rules needed for creating specific models

BPMN 2.0 Meta-model

- Metamodelling provides a number of benefits:
 - It formalizes the definition of models and entities
 - It formalizes the relationship between elements
 - It enables interoperability
- The new version's specification document has got **comprehensive UML class diagram** that graphically show the features of the different BPMN constructs and their relationships

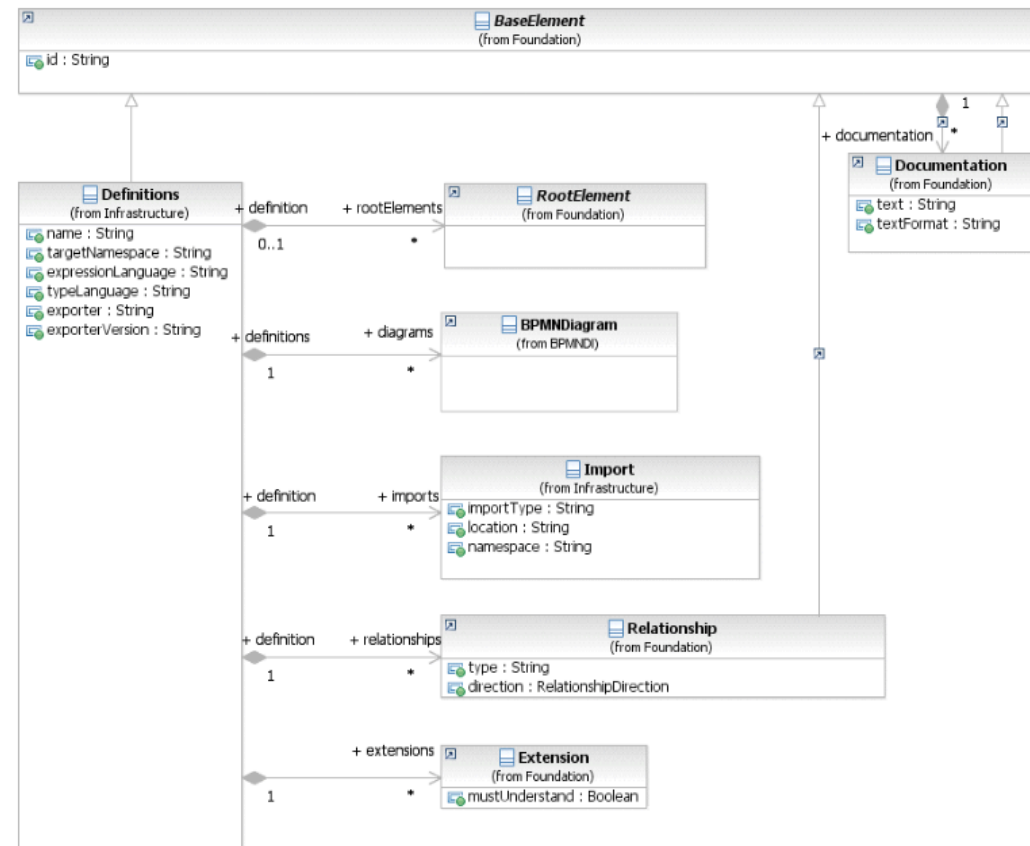

BPMN 1.2 vs BPMN 2.0

- The metamodel also has got additional language constructs that cannot be represented in the graphic models.
 - Such constructs are required by process engines to capture the necessary additional information for process execution.
- Moreover, the metamodel was the basis for the development on an **exchange format for BPMN models**
 - Up to now, it was almost impossible to transfer BPMN models from one tool into another.
 - Some tools have got import and export interfaces for the exchange of BPMN models by means of the XPD L format, but the use of XPD L for this purpose is not widely accepted yet.
 - Moreover, XPD L has not been implemented uniformly by all vendors, so that in practice there are quite often problems with model exchange

BPMN 2.0 (<http://www.bpmn.org/>)



Object Management Group Business Process Model and Notation



Home	Documents	Quick Guide	Examples	Implementers	Resources	Cloud Apps
----------------------	---------------------------	-----------------------------	--------------------------	------------------------------	---------------------------	----------------------------

Charter

A standard Business Process Model and Notation (BPMN) will provide businesses with the capability of understanding their internal business procedures in a graphical notation and will give organizations the ability to communicate these procedures in a standard manner. Furthermore, the graphical notation will facilitate the understanding of the performance collaborations and business transactions between the organizations. This will ensure that businesses will understand themselves and participants in their business and will enable organizations to adjust to new internal and B2B business circumstances quickly.



Search for a BPM term:

[Submit](#)

Current BPMN Specification

- [BPMN v2.0](#)
- [BPMN 2.0 by Example: non-normative OMG document with BPMN 2.0 examples](#)
- [BPMN Quick Guide](#)

BPM Certification



The [OCEB program](#) consists of five examinations, granting five Certifications. Above the single Fundamental level, the program splits into two tracks - one Business-oriented , the other Technically oriented.

BPMN 2.0 manifesto

BPMN 2.0 - Business Process Model and Notation

<http://bpmn.de/poster>

Activities

- Task**: A Task is a unit of work, the job to be performed. When marked with a [] symbol it indicates a Sub-Process, an activity that can be refined.
- Transaction**: A Transaction is a set of activities that logically belong together; it might follow a specified transaction protocol.
- Event Sub-Process**: An Event Sub-Process is placed into a Process or Sub-Process. It is activated when its start event gets triggered and can interrupt the higher-level process context or run in parallel (non-interrupting) depending on the start event.
- Call Activity**: A Call Activity is a wrapper for a globally defined Task or Process reused in the current Process. A call to a Process is marked with a [] symbol.

Activity Markers
Markers indicate execution behavior of activities:

- Sub-Process Marker
- Loop Marker
- Parallel MI Marker
- Sequential MI Marker
- Ad Hoc Marker
- Compensation Marker

Task Types
Types specify the nature of the action to be performed:

- Send Task
- Receive Task
- User Task
- Manual Task
- Business Rule Task
- Service Task
- Script Task

Sequence Flow: defines the execution order of activities.

Default Flow: is the default branch to be chosen if all other conditions evaluate to false.

Conditional Flow: has a condition that defines whether or not the flow is used.

Conversations

- A **Conversation** defines a set of logically related message exchanges. When marked with a [] symbol it indicates a Sub-Conversation, a compound conversation element.
- A **Call Conversation** is a wrapper for a globally defined Conversation or Sub-Conversation. A call to a Sub-Conversation is marked with a [] symbol.
- A **Conversation Link** connects Conversations and Participants.

Conversation Diagram

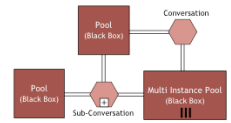

Choreographies

- A **Choreography Task** represents an Interaction (Message Exchange) between two Participants.
- A **Sub-Choreography** contains a refined choreography with several Interactions.
- A **Call Choreography** is a wrapper for a globally defined Choreography Task or Sub-Choreography. A call to a Sub-Choreography is marked with a [] symbol.

Choreography Diagram

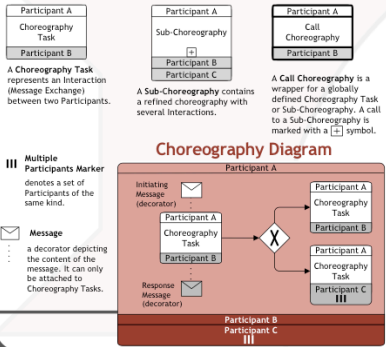

Events

	Start	Intermediate	End
Standard			
Event Sub-Process Interrupting			
Event Sub-Process Non-Interrupting			
Catching			
Boundary Interrupting			
Boundary Non-Interrupting			
Throwing			
Standard			

None: Untyped events, indicate start point, state changes or final states.

Message: Receiving and sending messages.

Timer: Cyclic timer events, points in time, time spans or timeouts.

Escalation: Escalating to an higher level of responsibility.

Conditional: Reacting to changed business conditions or integrating business rules.

Link: Off-page connectors. Two corresponding link events equal a sequence flow.

Error: Catching or throwing named errors.

Cancel: Reacting to cancelled transactions or triggering cancellation.

Compensation: Handling or triggering compensation.

Signal: Signalling across different processes. A signal thrown can be caught multiple times.

Multiple: Catching one out of a set of events. Throwing all events defined.

Parallel Multiple: Catching all out of a set of parallel events.

Terminate: Triggering the immediate termination of a process.

Collaboration Diagram

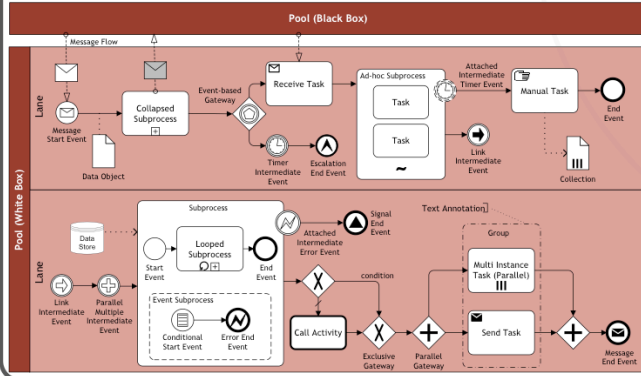

Gateways

- Exclusive Gateway**: When splitting, it routes the sequence flow to exactly one of the outgoing branches. When merging, it awaits one incoming branch to complete before triggering the outgoing flow.
- Event-based Gateway**: Is always followed by catching events or receive tasks. Sequence flow is routed to the subsequent event/task which happens first.
- Parallel Gateway**: When used to split the sequence flow, all outgoing branches are activated simultaneously. When merging parallel branches it waits for all incoming branches to complete before triggering the outgoing flow.
- Inclusive Gateway**: When splitting, one or more branches are activated. All active incoming branches must complete before merging.
- Exclusive Event-based Gateway (instantiated)**: Each occurrence of a subsequent event starts a new process instance.
- Complex Gateway**: Complex merging and branching behavior that is not captured by other gateways.
- Parallel Event-based Gateway (instantiated)**: The occurrence of all subsequent events starts a new process instance.

Swimlanes

Pools (Participants) and Lanes represent responsibilities/organizational boundaries. Message flow can be attached to pools, activities, or message events. The Message Flow can be decorated with an envelope depicting the content of the message.

The order of message exchanges can be specified by combining message flow and sequence flow.

Data

- Data Object**: represents information flowing through the process, such as business documents, e-mails, or letters.
- Collection Data Object**: represents a collection of information, e.g., a list of order items.
- Data Input**: is an external input for the entire process. A kind of input parameter.
- Data Output**: is data result of the entire process. A kind of output parameter.
- Data Association**: is used to associate data elements to Activities, Processes and Global Tasks.
- Data Store**: is a place where the process can read or write data, e.g., a database or a filing cabinet. It persists beyond the lifetime of the process instance.



© 2011

BPMN 2.0 - models

- **Processes**, including
 - Private (internal) **Business Processes**
 - **Public Processes**
- **Choreographies**
- **Collaborations**, which can include **Processes** and/or **Choreographies**
 - A view of **Conversations**

BPMN 2.0 model types

Process



Collaboration

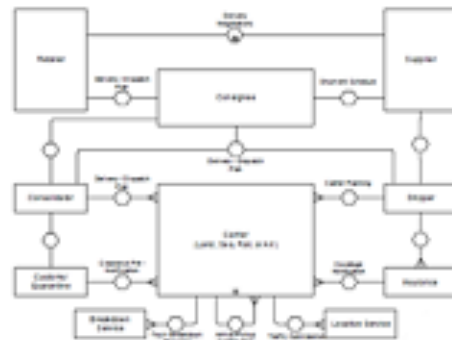
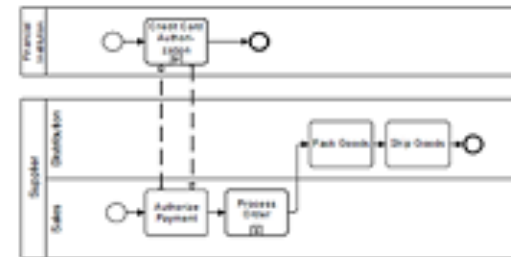

Conversation

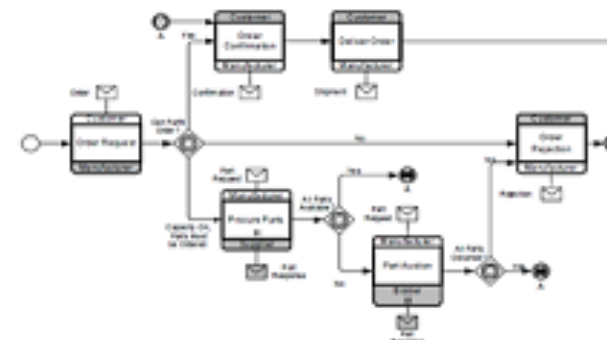

Choreography

Process: Private Business Process (executable or not)

Private Business Processes are those internal to a specific organization.

An Example:



- An *executable Process* is a **Process** that has been modeled for the purpose of being executed according to the semantics
- A non-executable **Process** is a *private Process* that has been modeled for the purpose of documenting **Process** behavior at a modeler-defined level of detail. Thus, information needed for execution, such as formal condition Expressions are typically not included in a *non-executable Process*.

Process: Public Business Process

A *public* **Process** represents the interactions between a *private* **Business Process** and another **Process** or *Participant*

An Example:

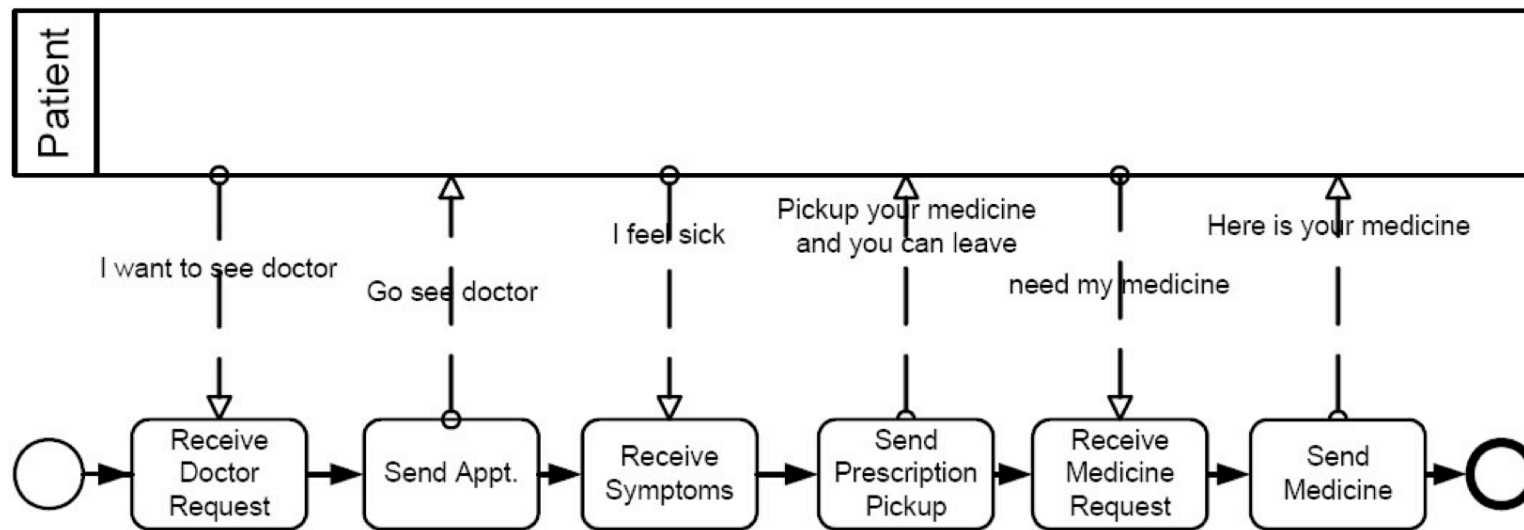

Collaboration Diagram

A **Collaboration** depicts the interactions between two or more business entities

An Example:

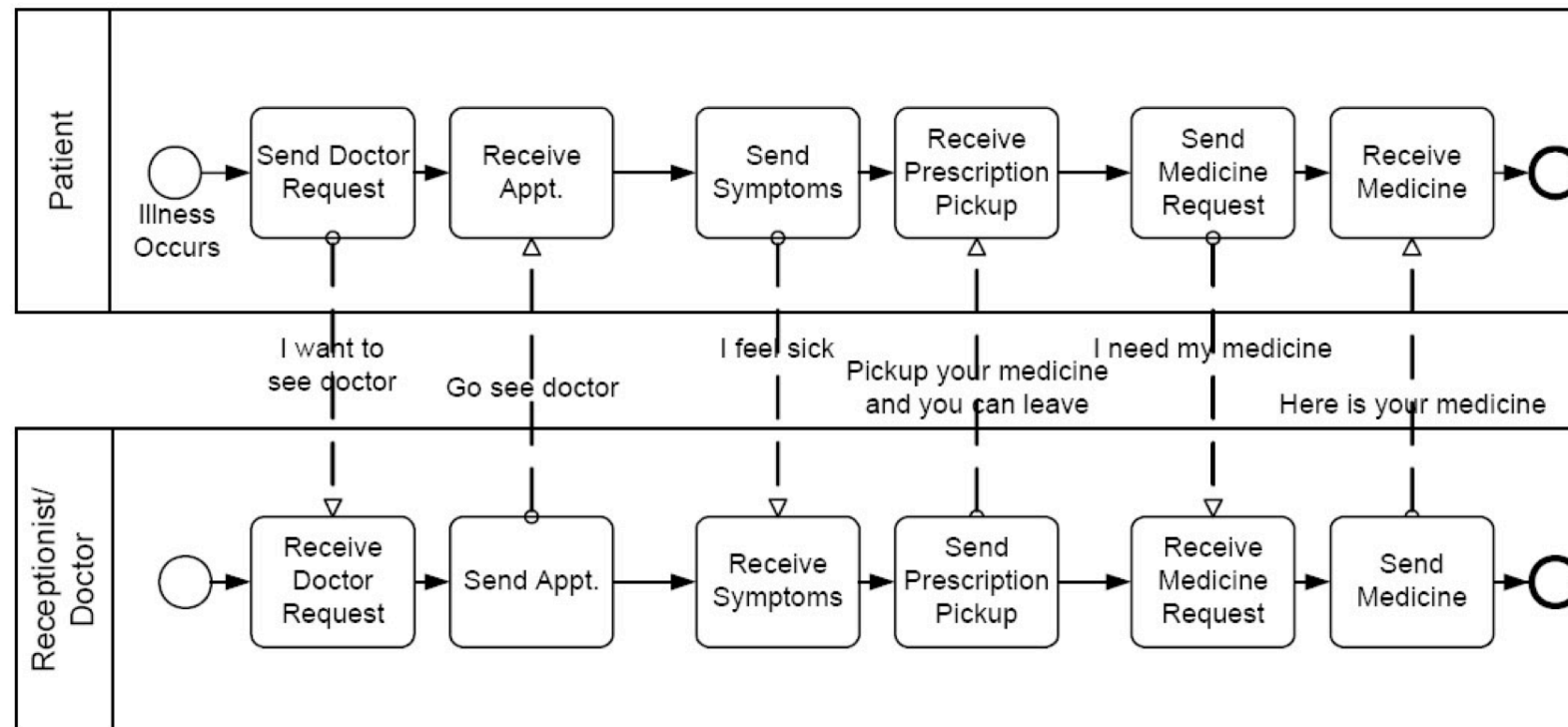

Choreography

- A self-contained **Choreography** is a definition of the expected behavior, basically a procedural contract, between interacting *Participants*
- While a normal **Process** exists within a **Pool**, a **Choreography** exists between **Pools** (or *Participants*)

An Example:

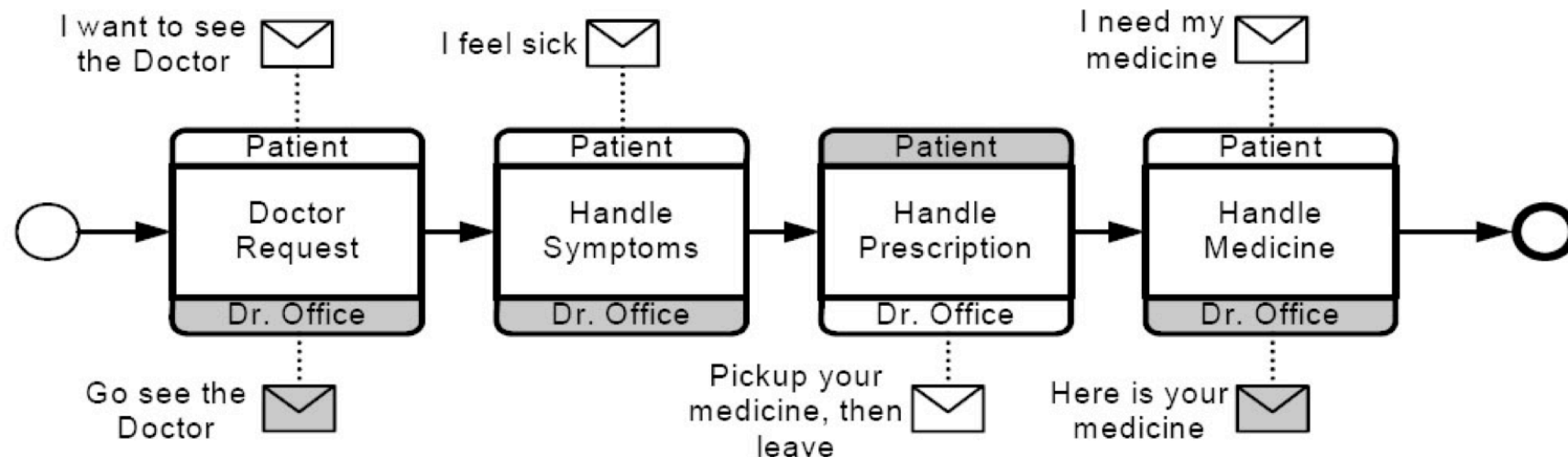

Conversation Diagram

- The **Conversation** diagram is a particular usage of and an informal description of a **Collaboration** diagram
- A **Conversation** is the logical relation of **Message** exchanges

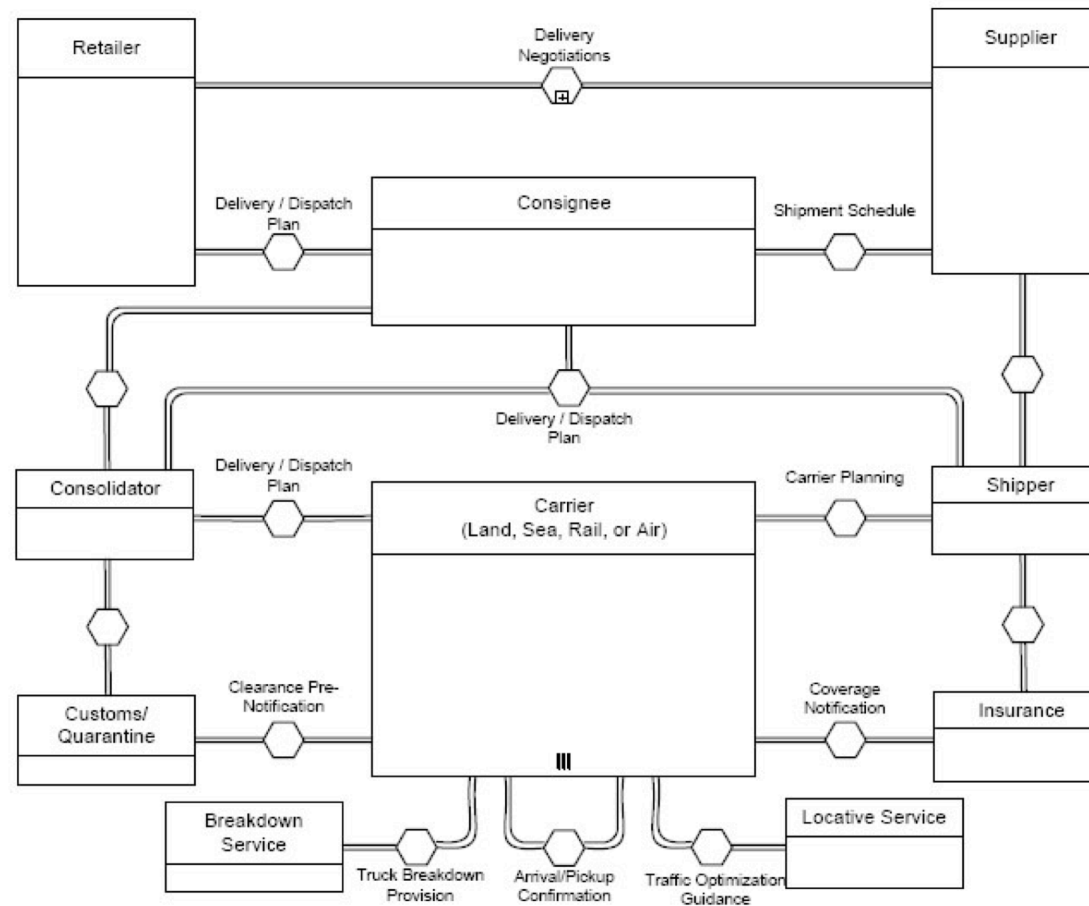



Process / Collaboration Diagram

Business Process Management and Flexibility

Barbara Re, Phd

Basic Elements

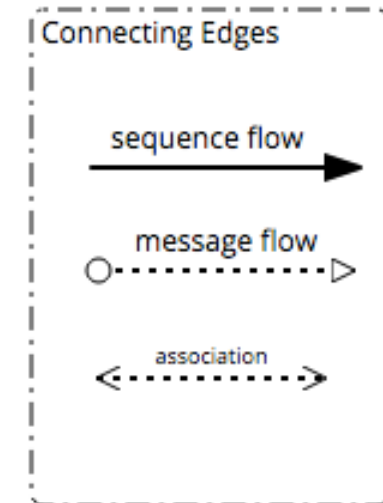
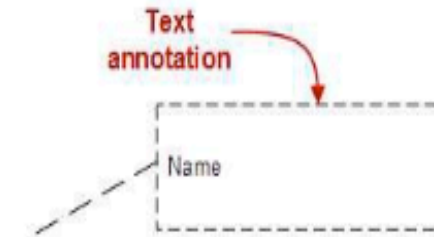
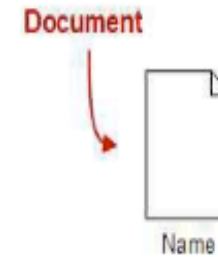
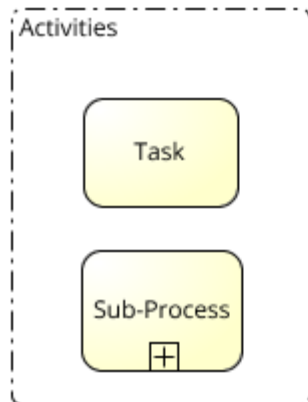
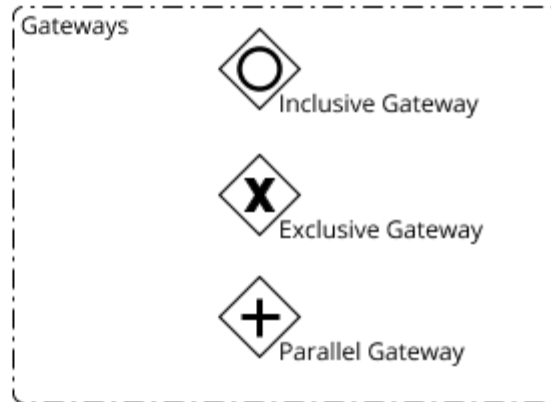
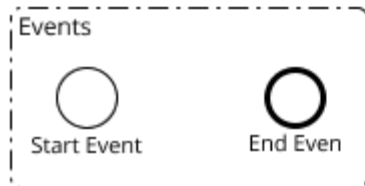

Used for simple business process modelling, understood by majority of business process related stakeholders

Basic Elements

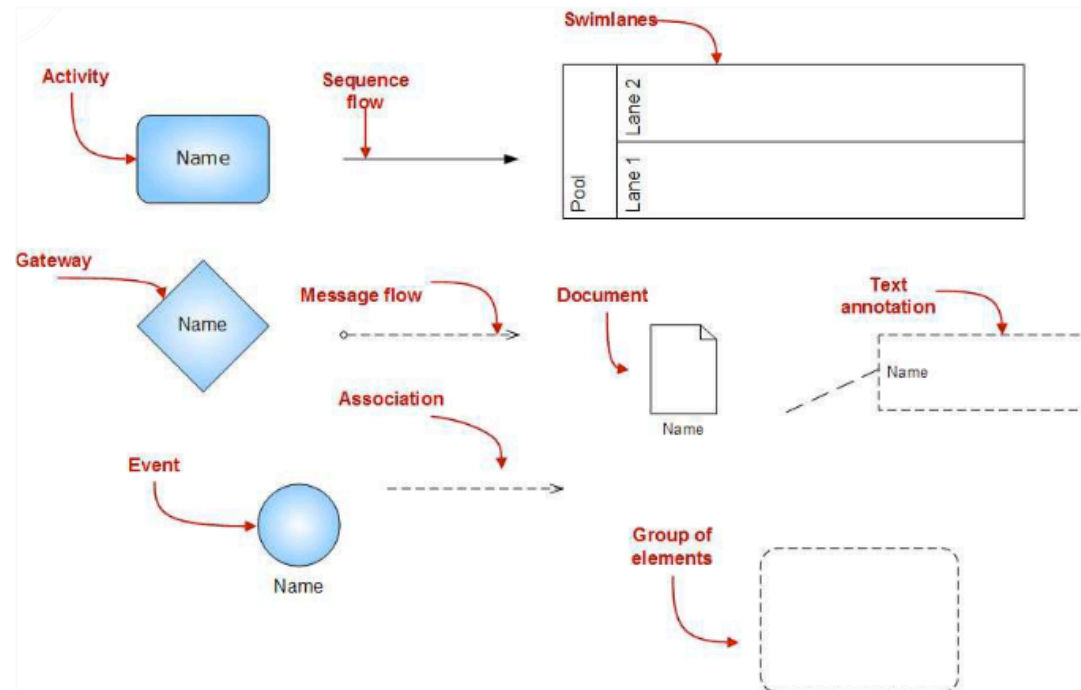

Used for simple business process modelling, understood by majority of business process related stakeholders

Simple BP model in BPMN

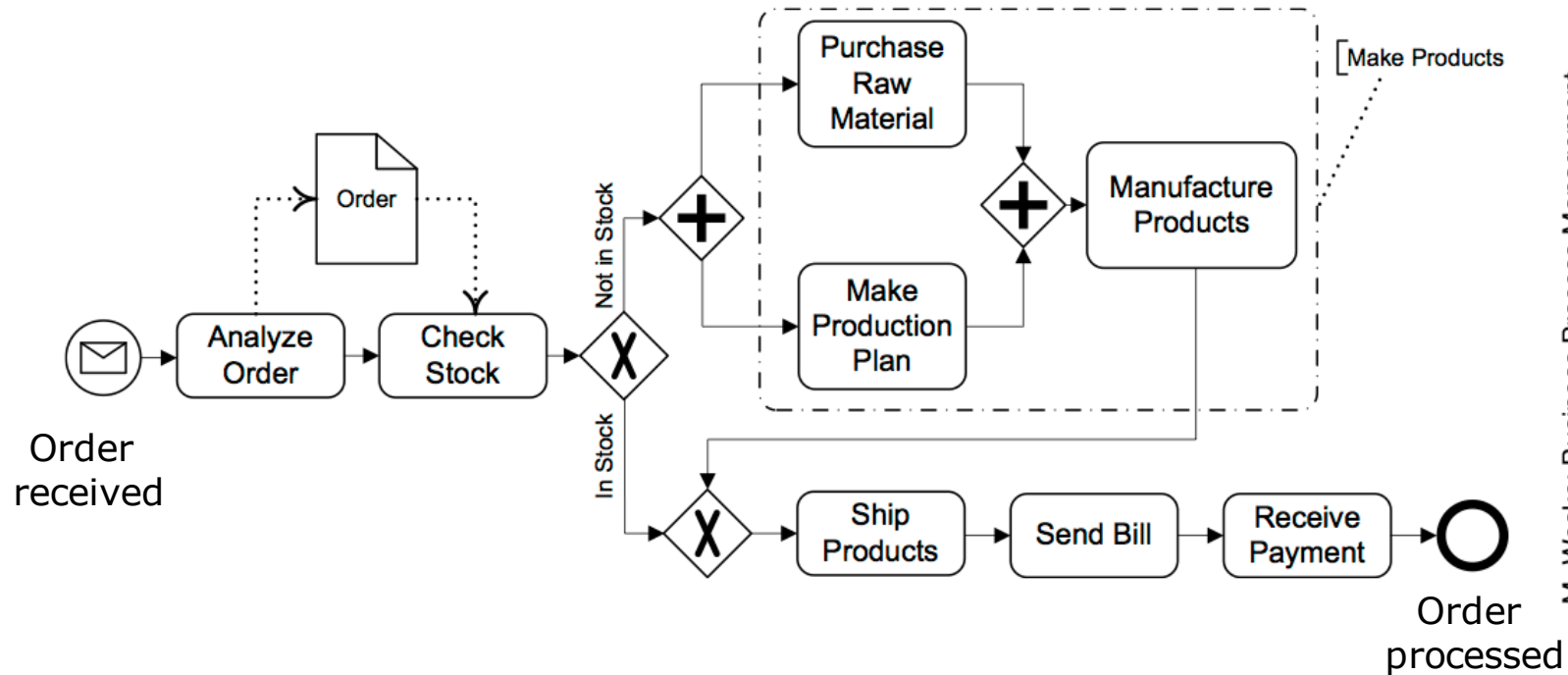

M. Weske: Business Process Management,
© Springer-Verlag Berlin Heidelberg 2012, 2007

Resources

- BPMN provides two constructs to model resource aspects:
 - **Pools** are generally used to model resource classes
 - **Lanes** are used to partition a pool into sub-classes or single resources. Lanes can be nested within each other in multiple levels.
- There are no constraints as to what specific resource type a **pool** or a **lane** should model
 - We would typically use:
 - A pool to model a *business party* like a whole organization
 - A lane to model a department, unit, team or software system/equipment within that organization

Simple BP model with resources information

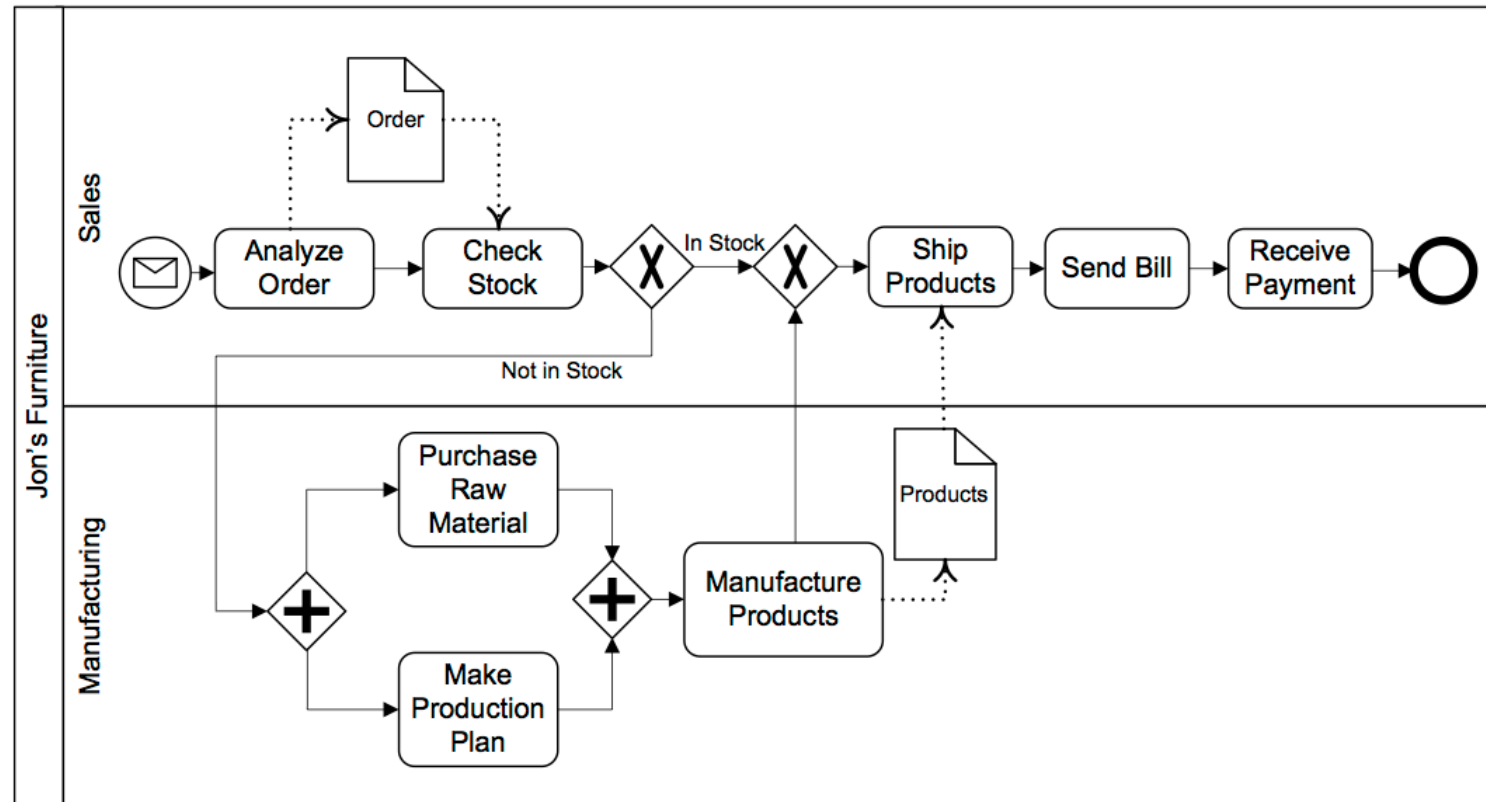

M. Weske: Business Process Management,
© Springer-Verlag Berlin Heidelberg 2012, 2007

Message Flow

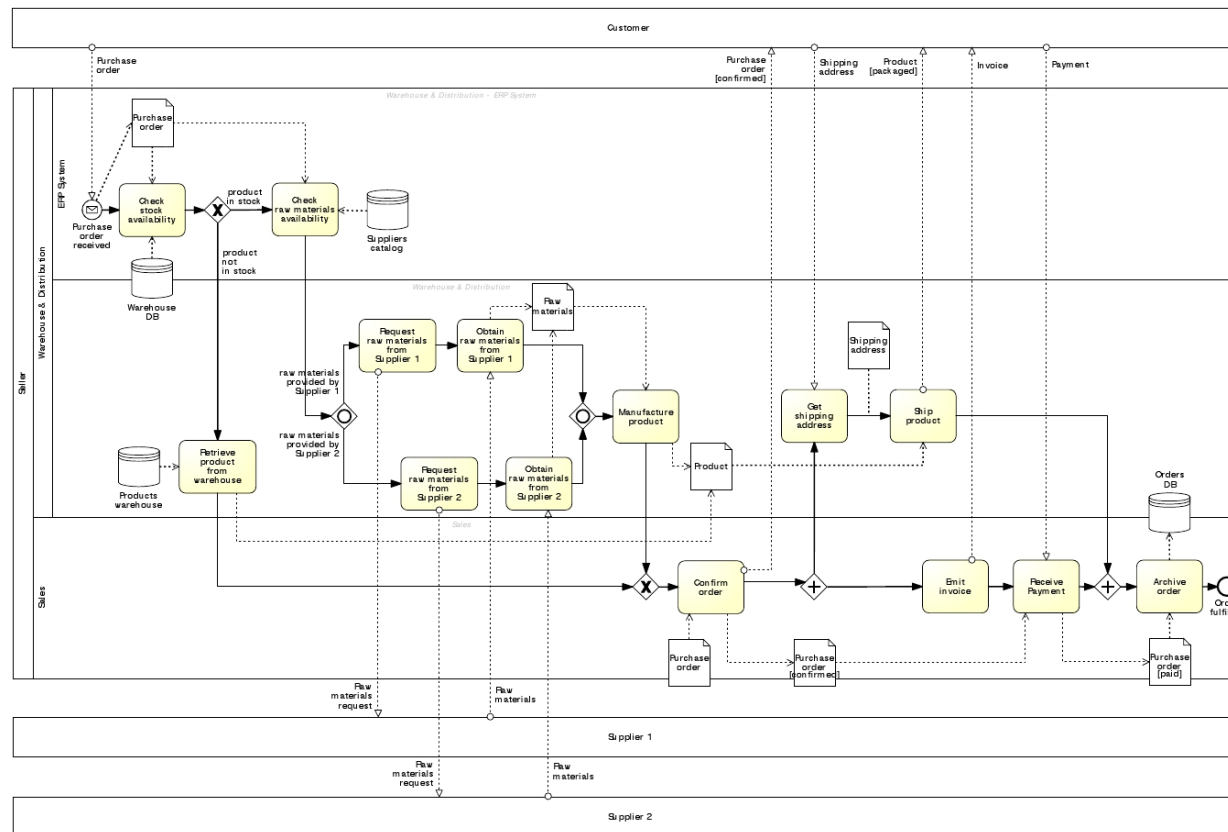

- ▶ A message flow represents the flow of information between two separate resource classes (pools)

Black box or white box?

- Modeling a pool as a white box or as a black box is a matter of relevance
- When working on a collaboration diagram, an organization may decide whether or not to expose their internal behavior depending on the requirements of the project at hand

BP collaboration – message flow

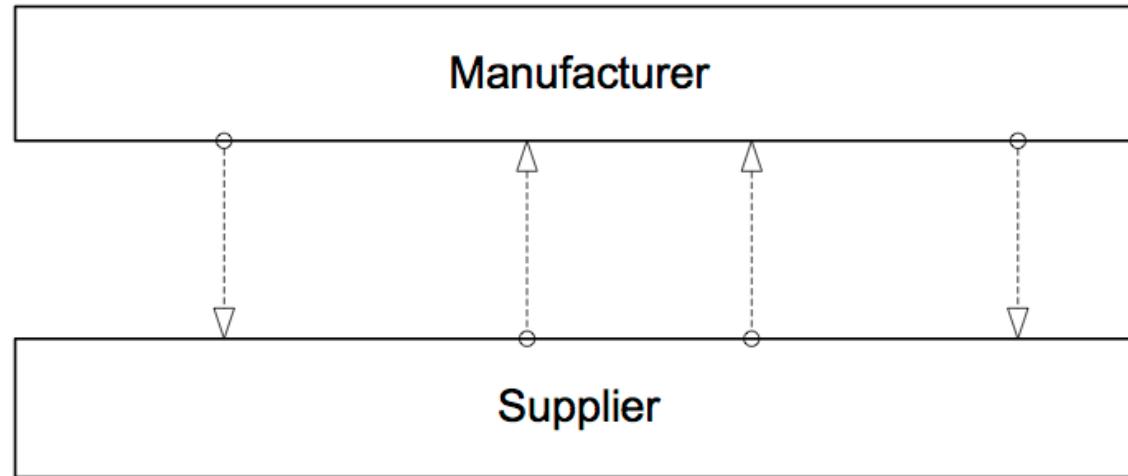

M. Weske: Business Process Management,
© Springer-Verlag Berlin Heidelberg 2012, 2007

BP collaboration with one public process (supplier)

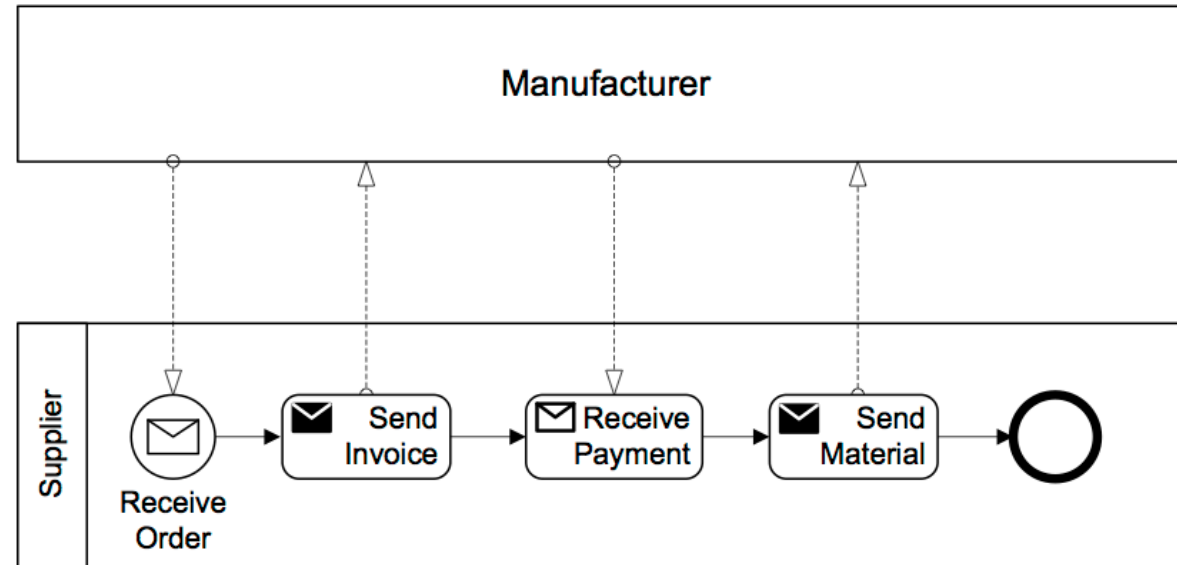

M. Weske: Business Process Management,
© Springer-Verlag Berlin Heidelberg 2012, 2007

BP collaborating with two public process

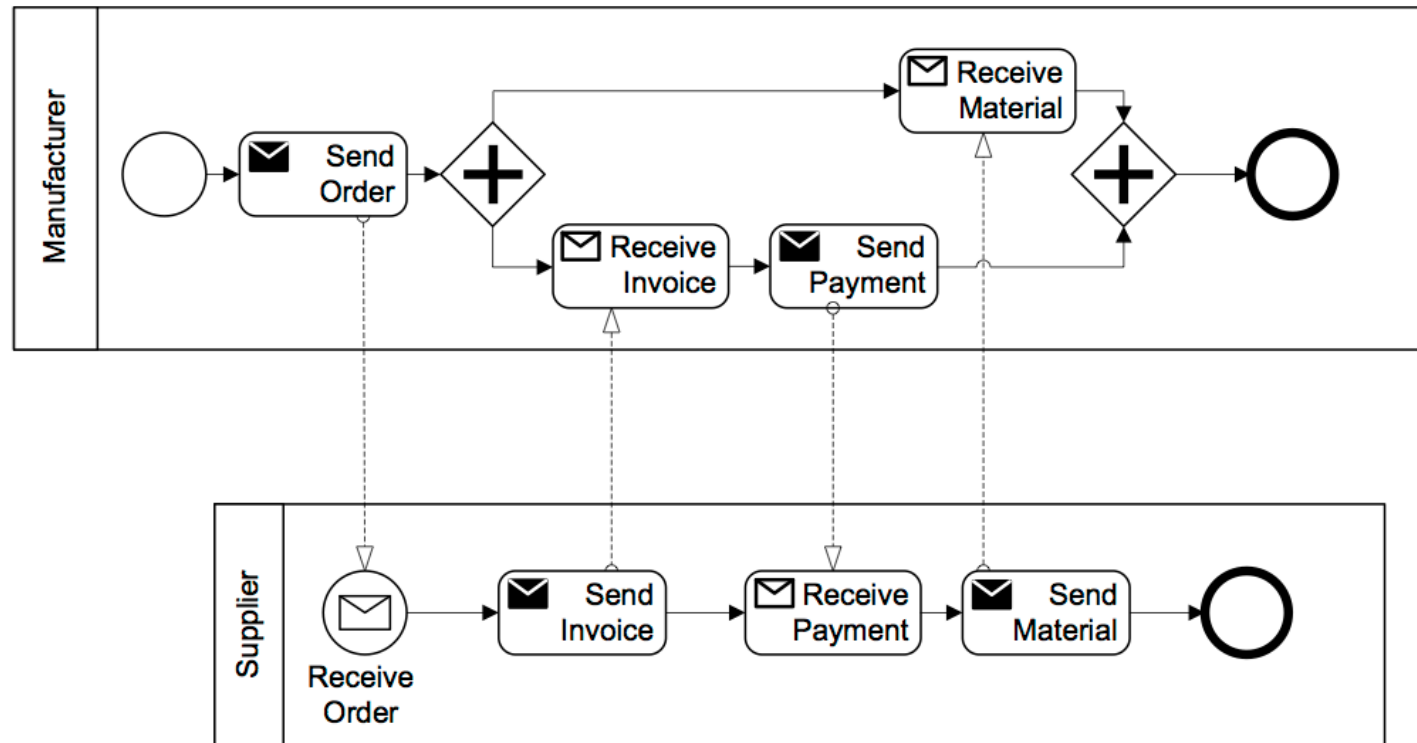

M. Weske: Business Process Management,
© Springer-Verlag Berlin Heidelberg 2012, 2007

Multiple instance pool

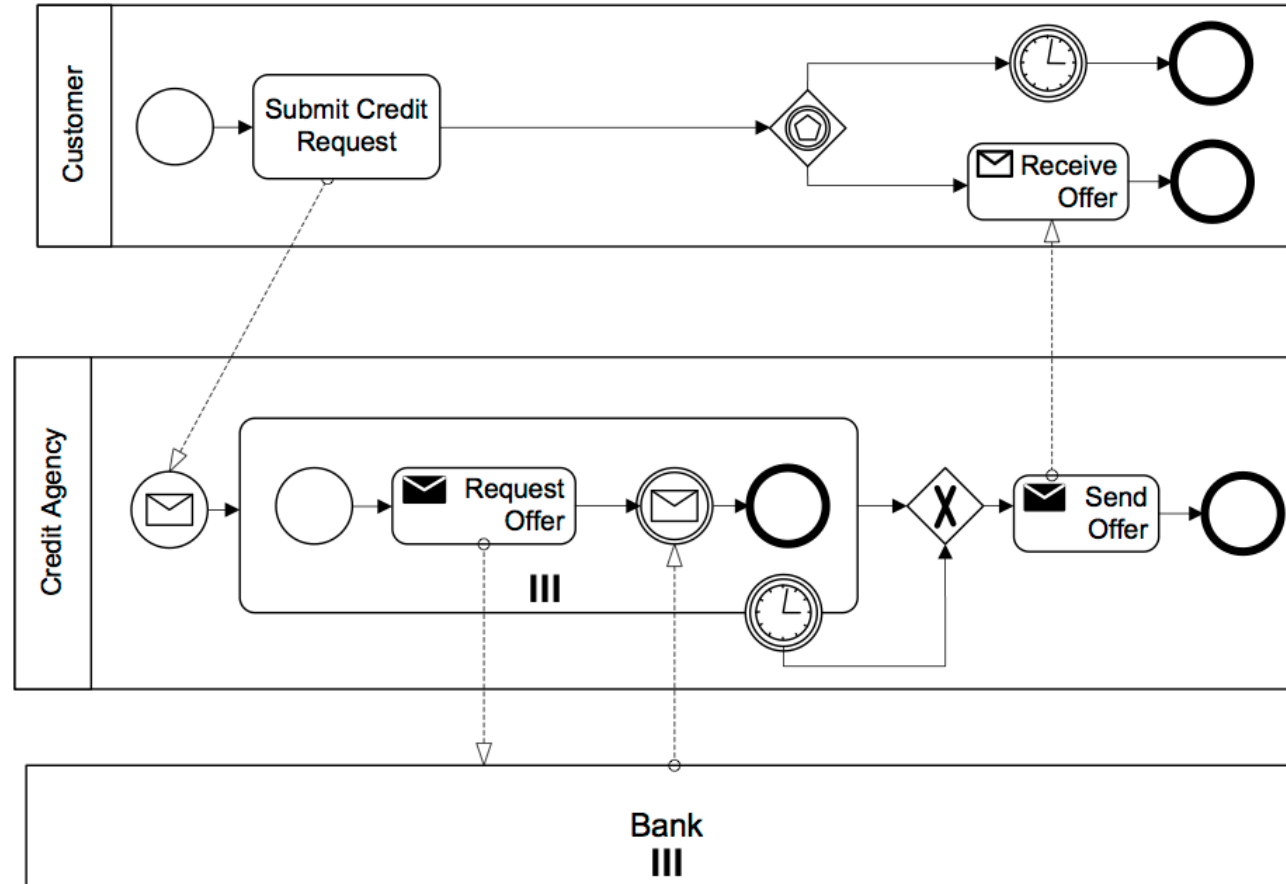

M. Weske: Business Process Management,
© Springer-Verlag Berlin Heidelberg 2012, 2007

Activity types in the BPMN

An atomic activity, also called *task*, is an activity capturing a unit of work that cannot be further broken down

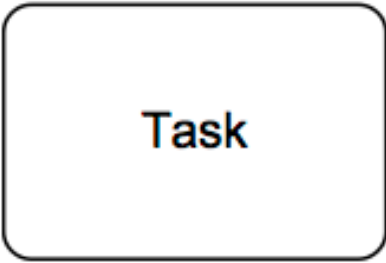

Task



Transaction

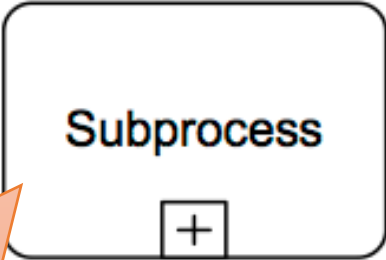







Subprocess



Call Activity

A sub-process represents a self-contained, composite activity that can be broken down into smaller units of work

Activity Markers

-  Subprocess Marker
-  Loop Marker
-  Parallel MI Marker
-  Sequential MI Marker
-  Adhoc Marker
-  Compensation Marker

M. Weske: Business Process Management,
© Springer-Verlag Berlin Heidelberg 2012, 2007

Task types



Send Task



Receive Task



User Task



Manual Task



Business Rule Task



Service Task



Script Task

- A send task is a task that send a message. Once the message is sent, the task is completes
- A receive task is a task that waits to receive a message. Once the message arrives, the task completes
- User tasks represent traditional workflow tasks that involve user interaction
- Manual activities are performed without the support of software systems.
- A Business Rule task is used to synchronously execute one or more rules.
- A service task is a task that is implemented by a piece of software, either using a Web services interface or an application programming interface to a software system.
- A script task is a task that uses some scripting language expression in order to be performed. Script tasks are used to represent simple functionality, for which no dedicated software system is required.

Collapsed and expanded sub-process

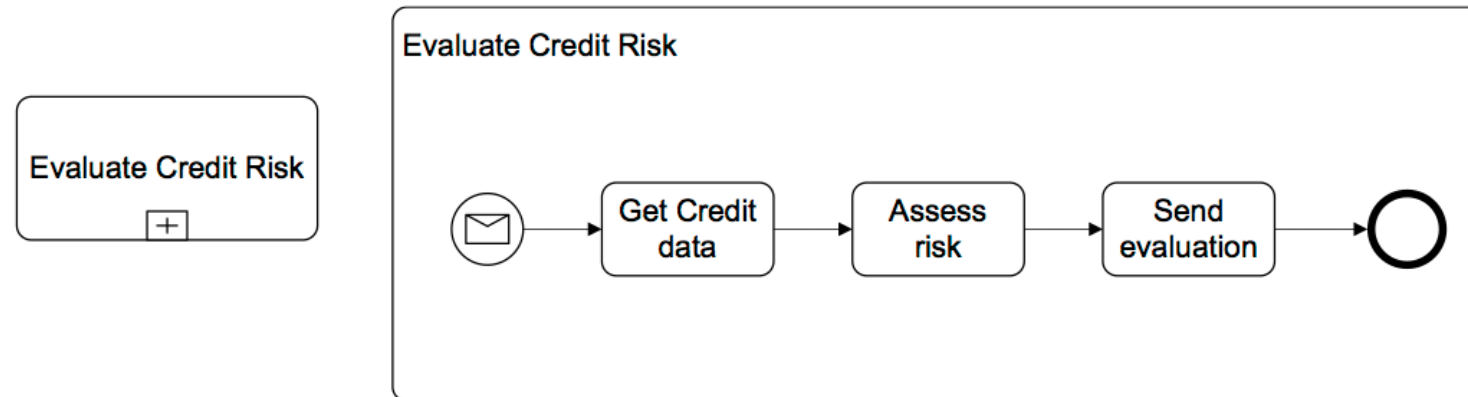

M. Weske: Business Process Management,
© Springer-Verlag Berlin Heidelberg 2012, 2007

Anything wrong with this model?

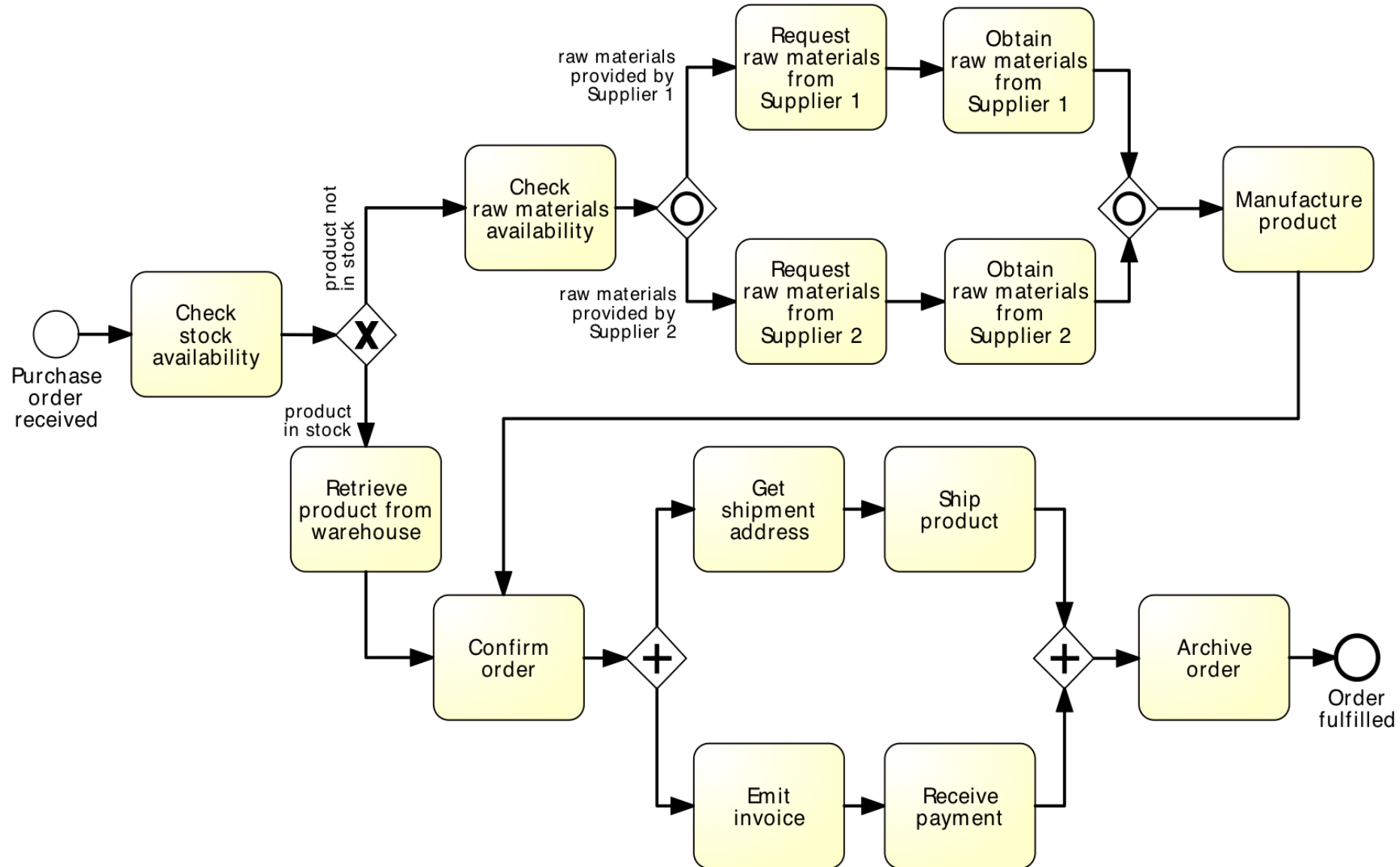

Is this better?

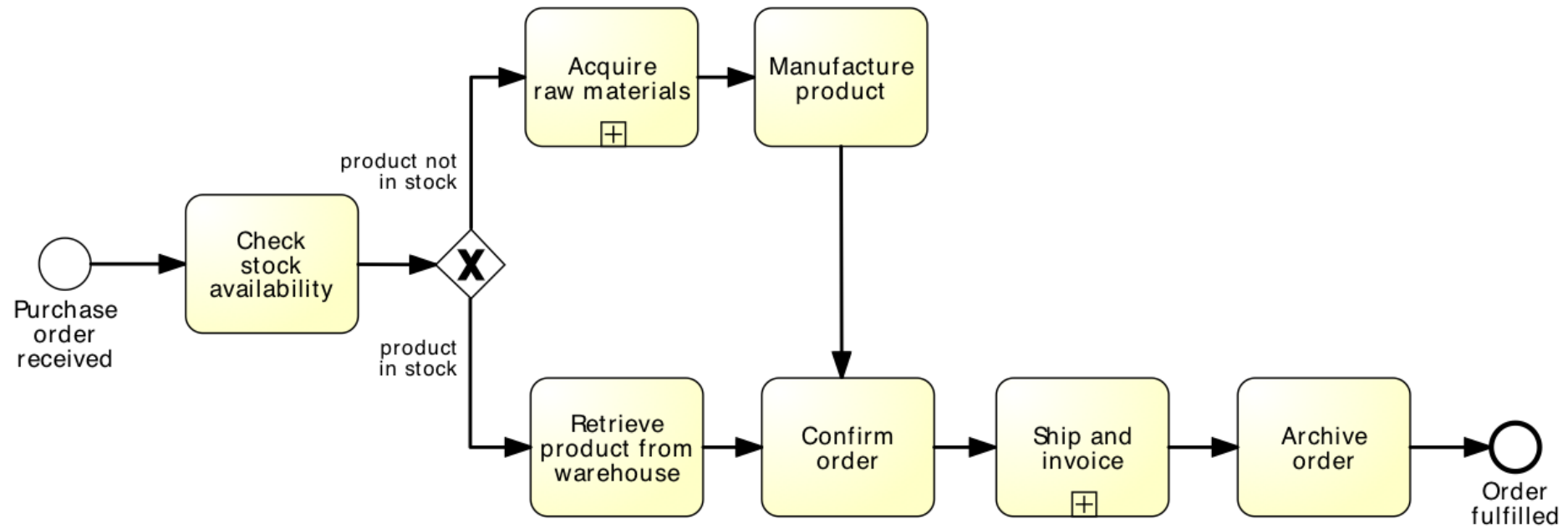

Expanded...

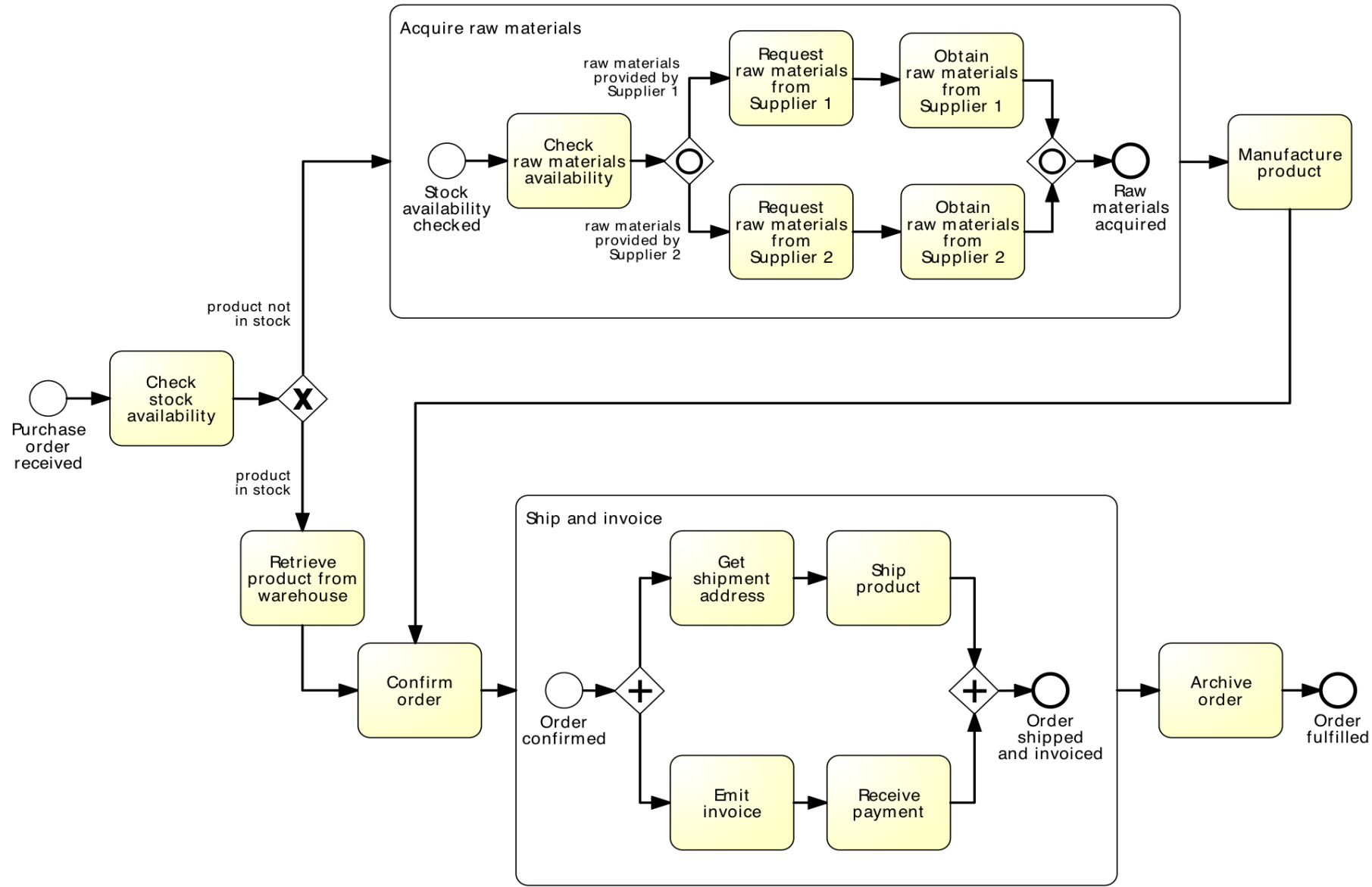

Use of Sub-processes

1. Break down large models into smaller ones, making them easier to understand and maintain
 - process hierarchies: we can nest sub-processes in multiple levels, so as to decompose a process model hierarchically
2. Share common fragments across multiple processes
 - shared sub-processes
3. Identify parts of a process that should be repeated

Process hierarchies

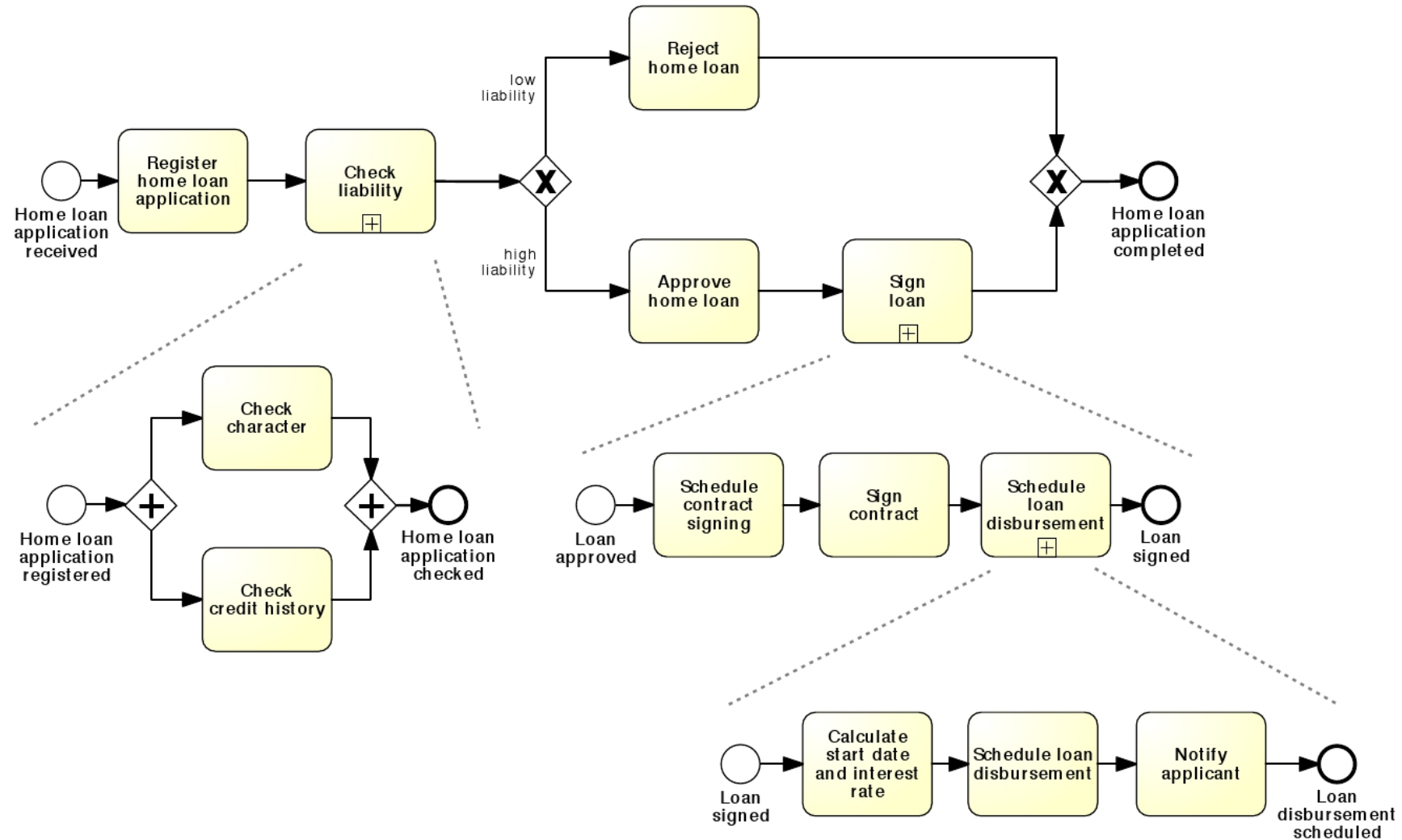

Share common fragments across multiple processes: Call Activity

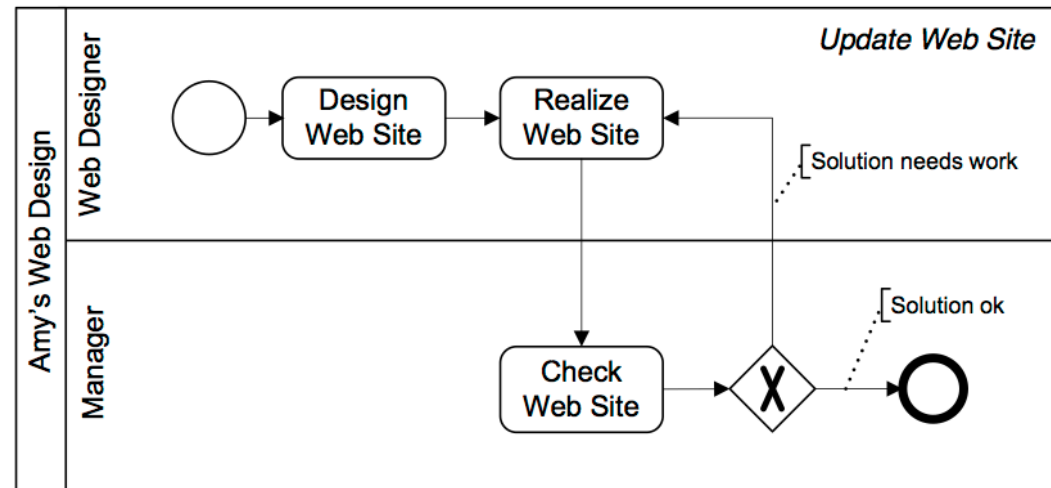
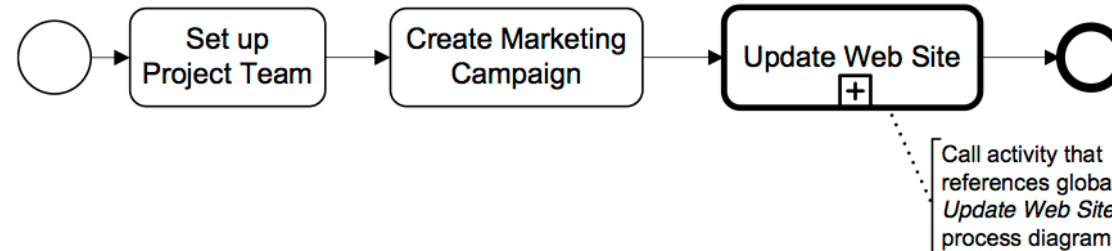

M. Weske: Business Process Management,
© Springer-Verlag Berlin Heidelberg 2012, 2007

The call activity refers to a process model that can be invoked by more than one process
In the same process model collection

Share common fragments across multiple processes: example

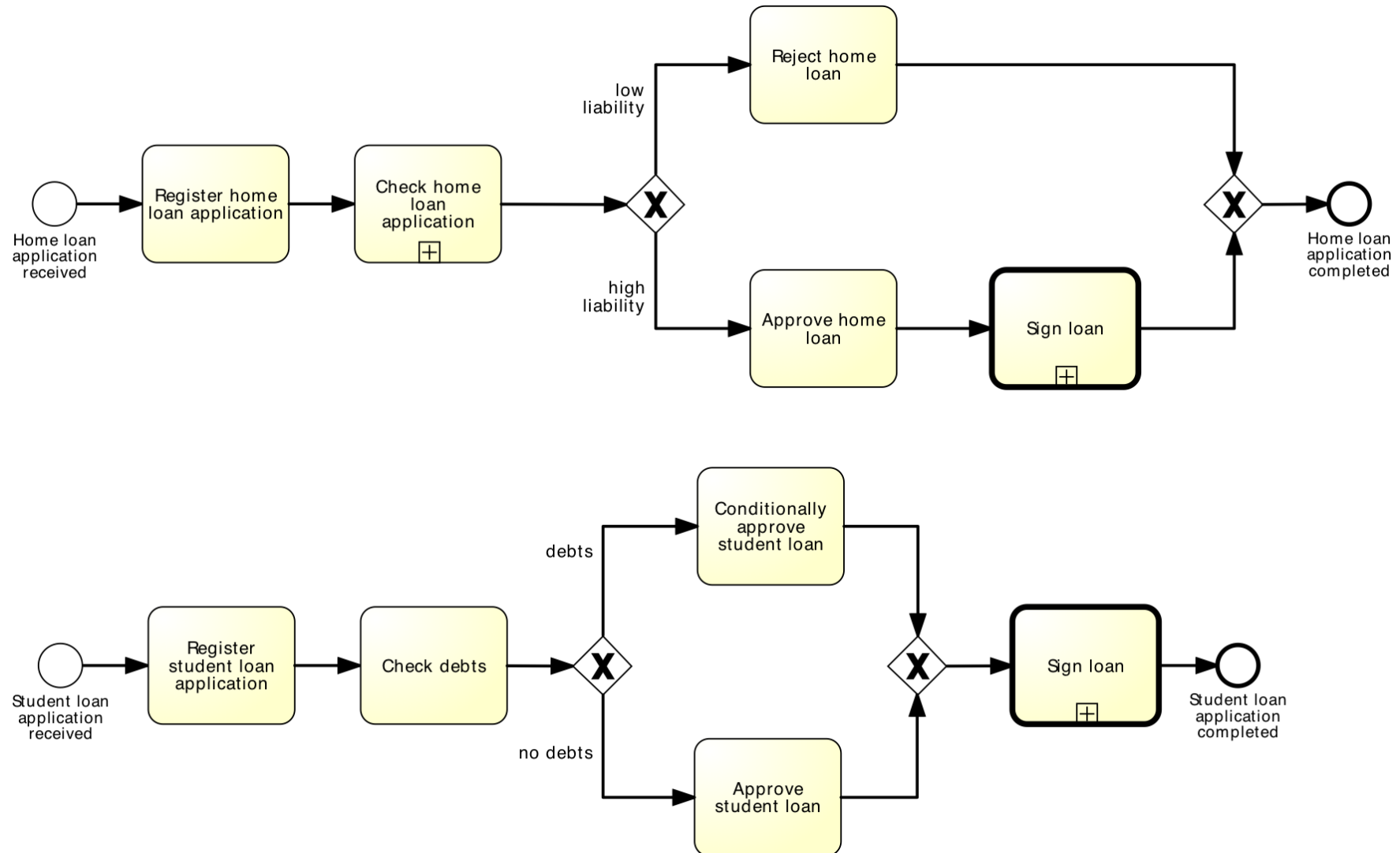

Call Activity: reusability and maintenance

- Our default choice should be to define sub-processes as global process models so as to **maximize their reusability** within our process model collection
 - Supporting processes such as payment, invoicing, HR, printing, are good candidates for being defined as global process models, since they are typically shared by various business processes within an organization
- Besides reusability, another advantage of using global process models is that **any change made to these models will be automatically propagated to all process models** that invoke them

Identify parts of a process that should be repeated

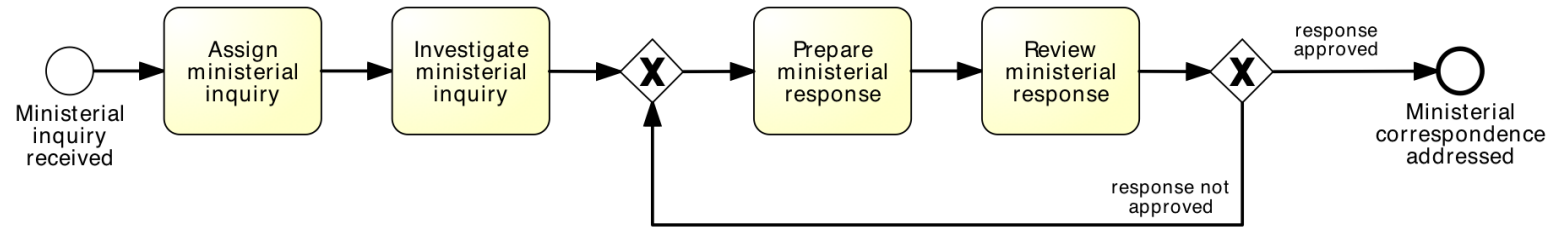

equivalent to:

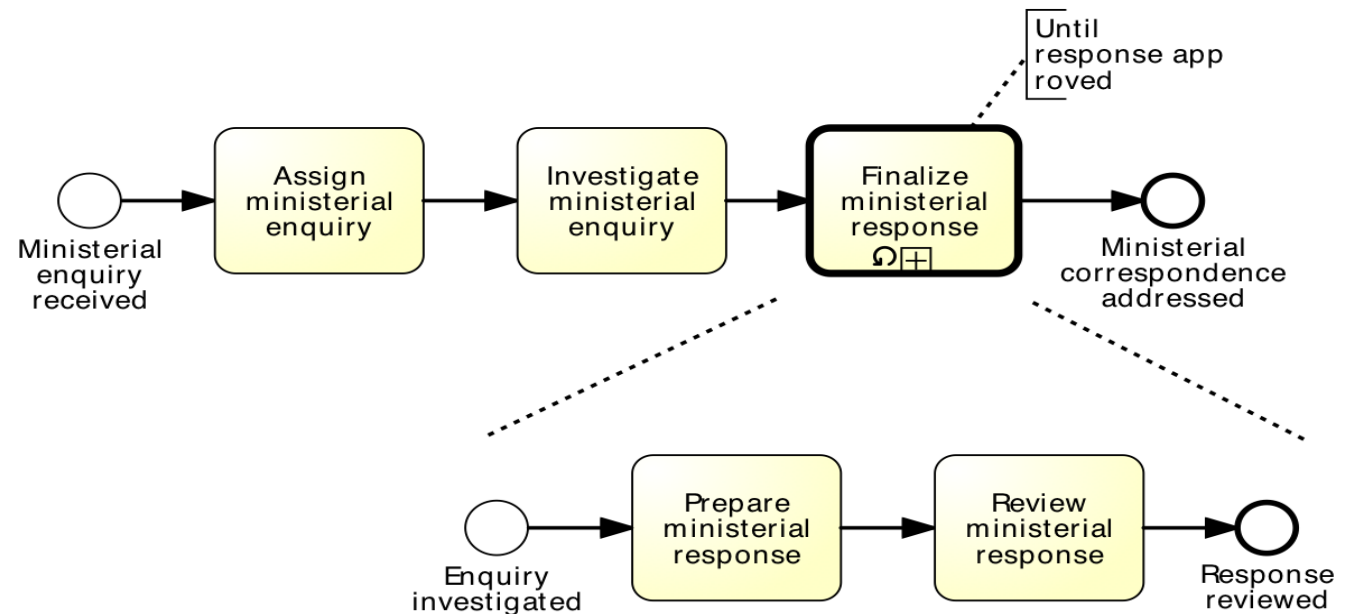

Identify parts of a process that should be executed multiple time in parallel

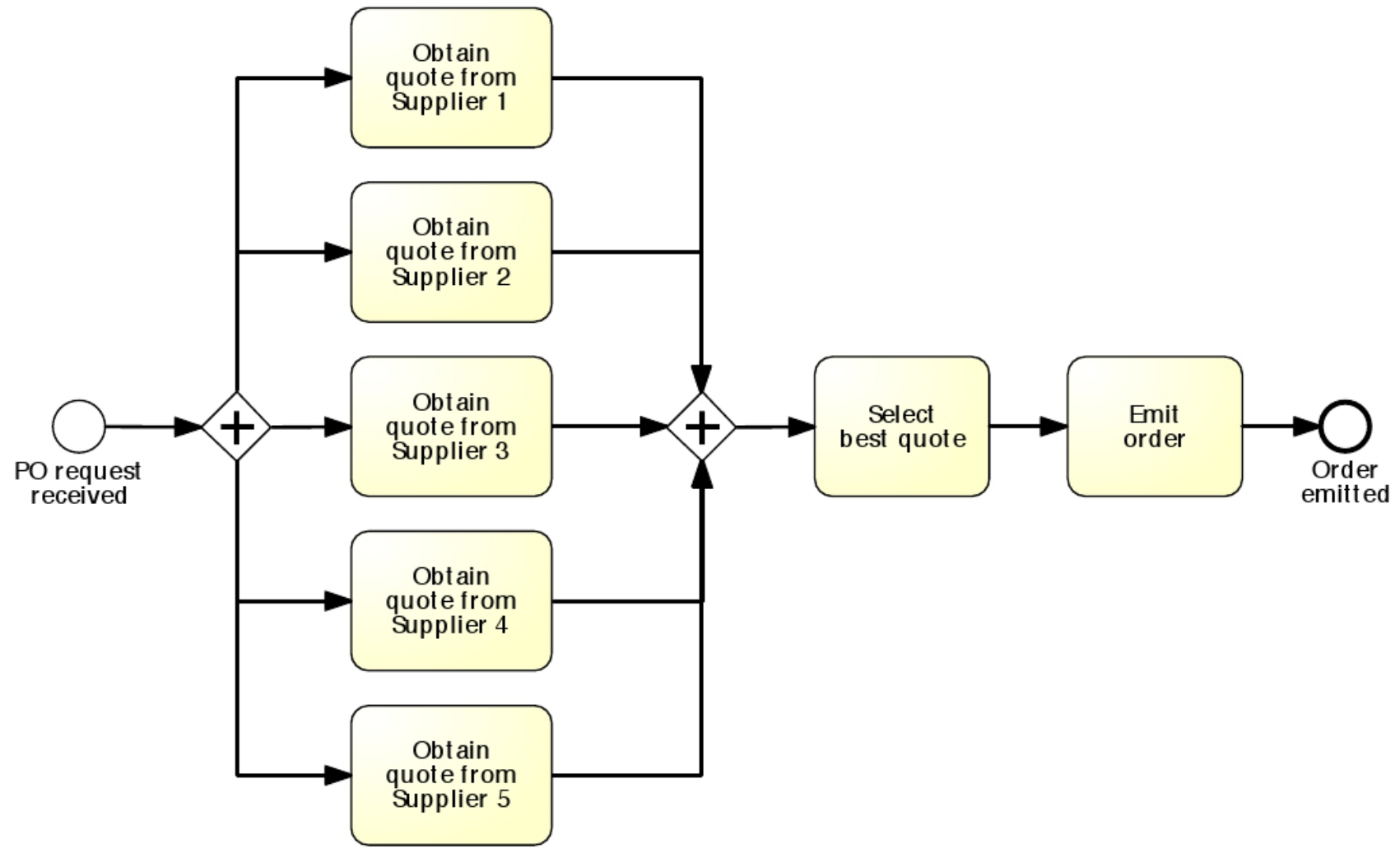

More On the Loop

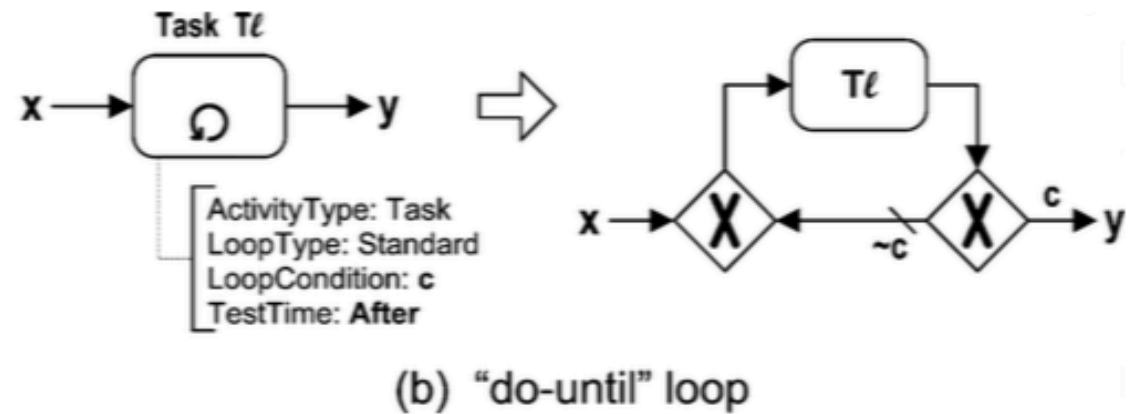
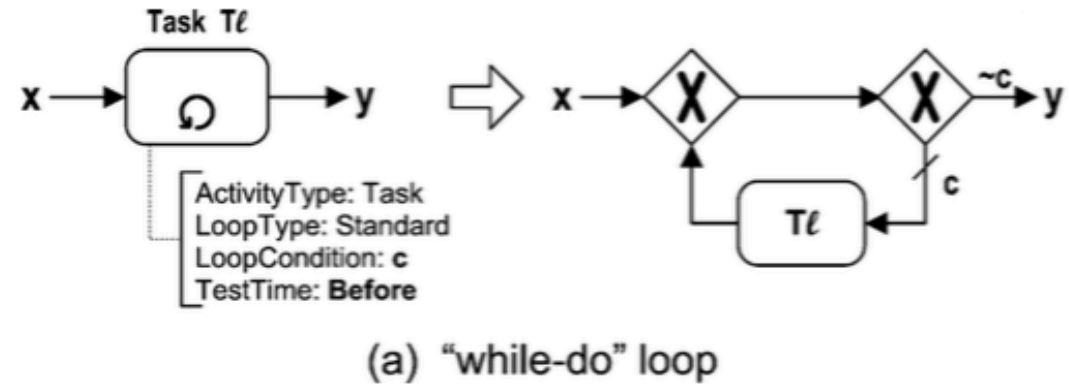

Use of Multiple-Instance Activity (in parallel)

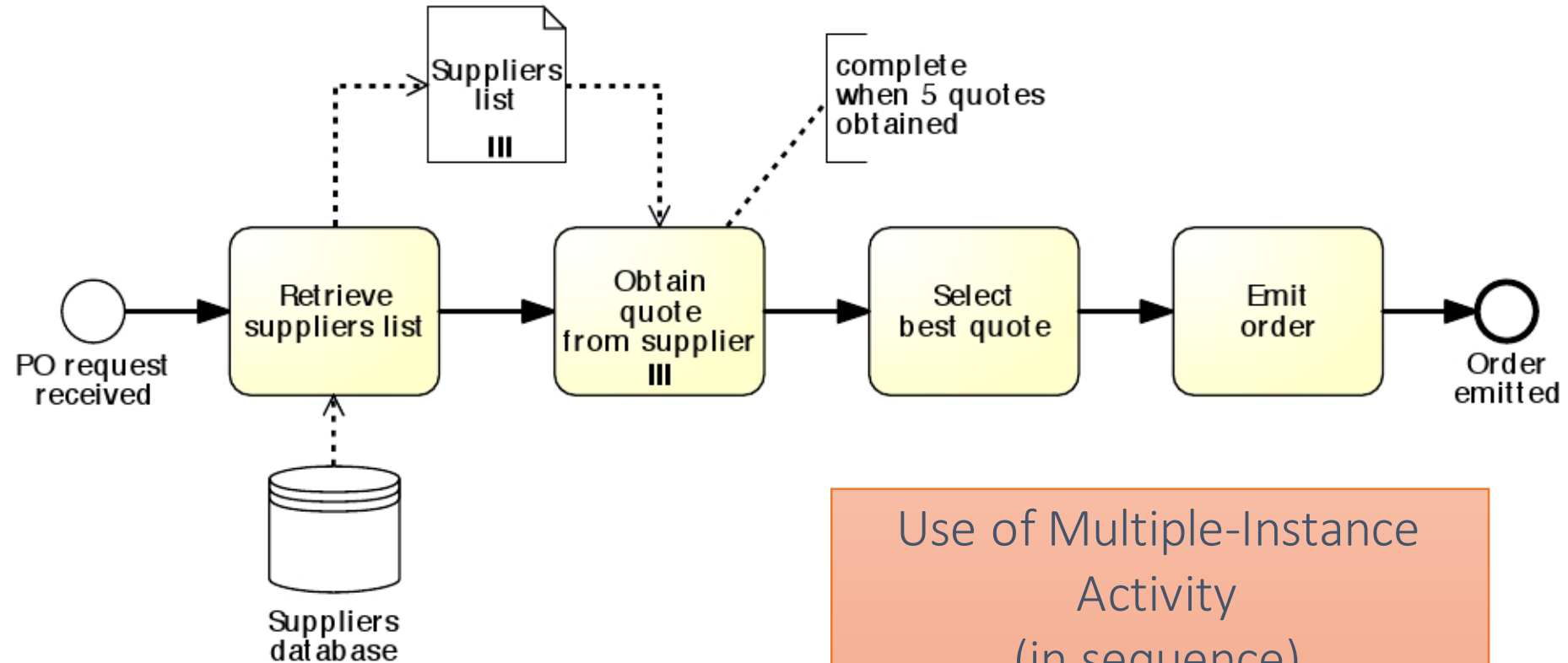

Use of Multiple-Instance Activity (in sequence)

≡ Sequential MI Marker

Exercise - Model the following process fragment

After a car accident, a statement is sought from two witnesses out of the five that were present, in order to lodge the insurance claim.

As soon as the first two statements are received, the claim can be lodged with the insurance company without waiting for the other statements.

Solution

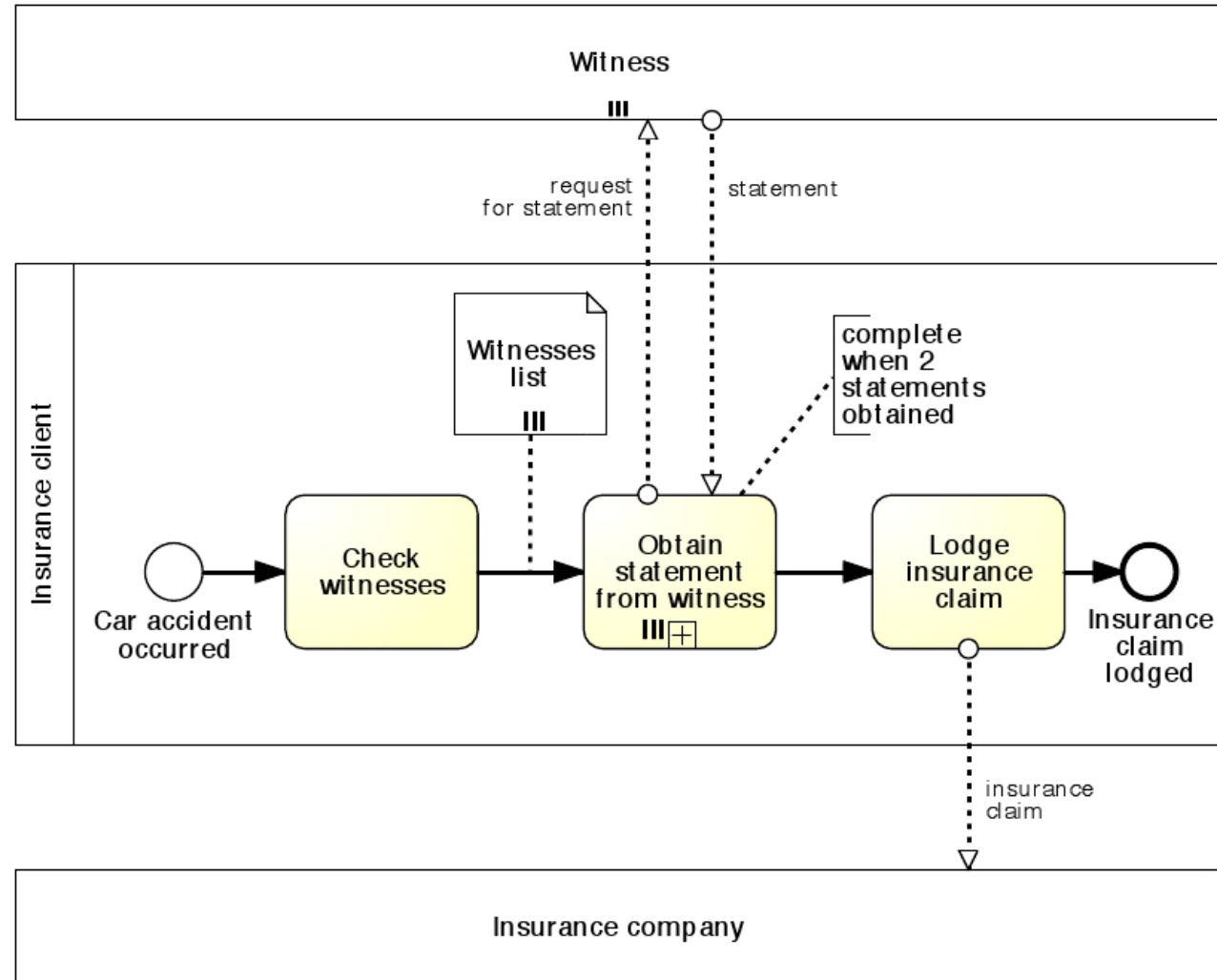

Uncontrolled Repetition: Sample adhoc process

Sometimes we may need to model that one or more activities can be repeated a number of times, without a specific order, until a condition is met.

These activities are **uncontrolled**, in the sense that they may be repeated multiple times with no specific order, or not occur at all, until a condition is met—in our case the order being fulfilled.

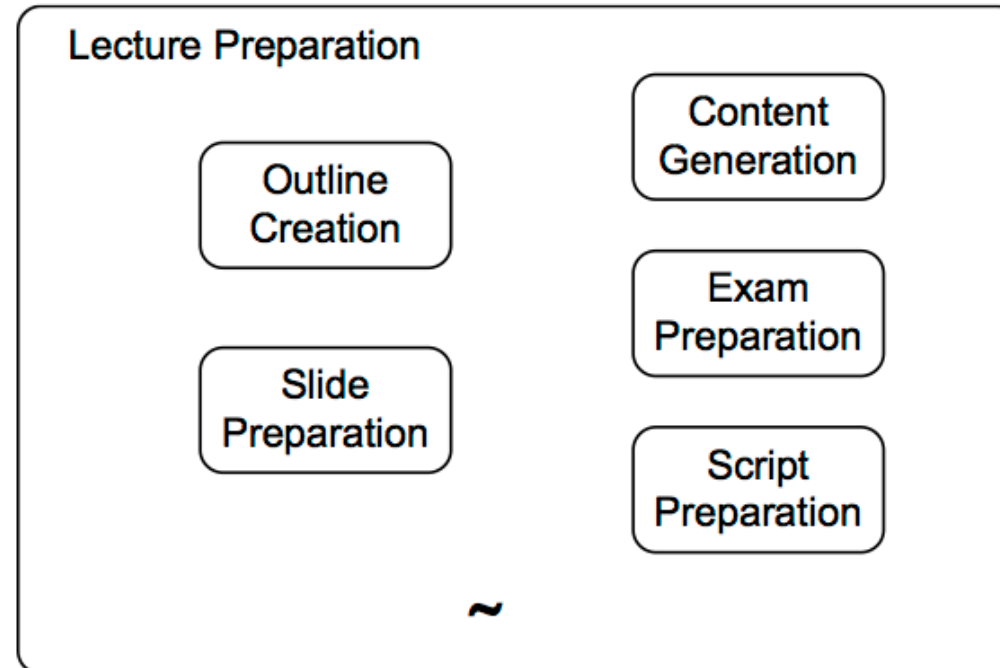

M. Weske: Business Process Management,
© Springer-Verlag Berlin Heidelberg 2012, 2007

A **partial order may be established** among the activities of an ad-hoc sub-process via the sequence flow. However, **we cannot represent start and end events** in an ad-hoc sub-process.

Using an ad-hoc sub-process to model uncontrolled repetition: example

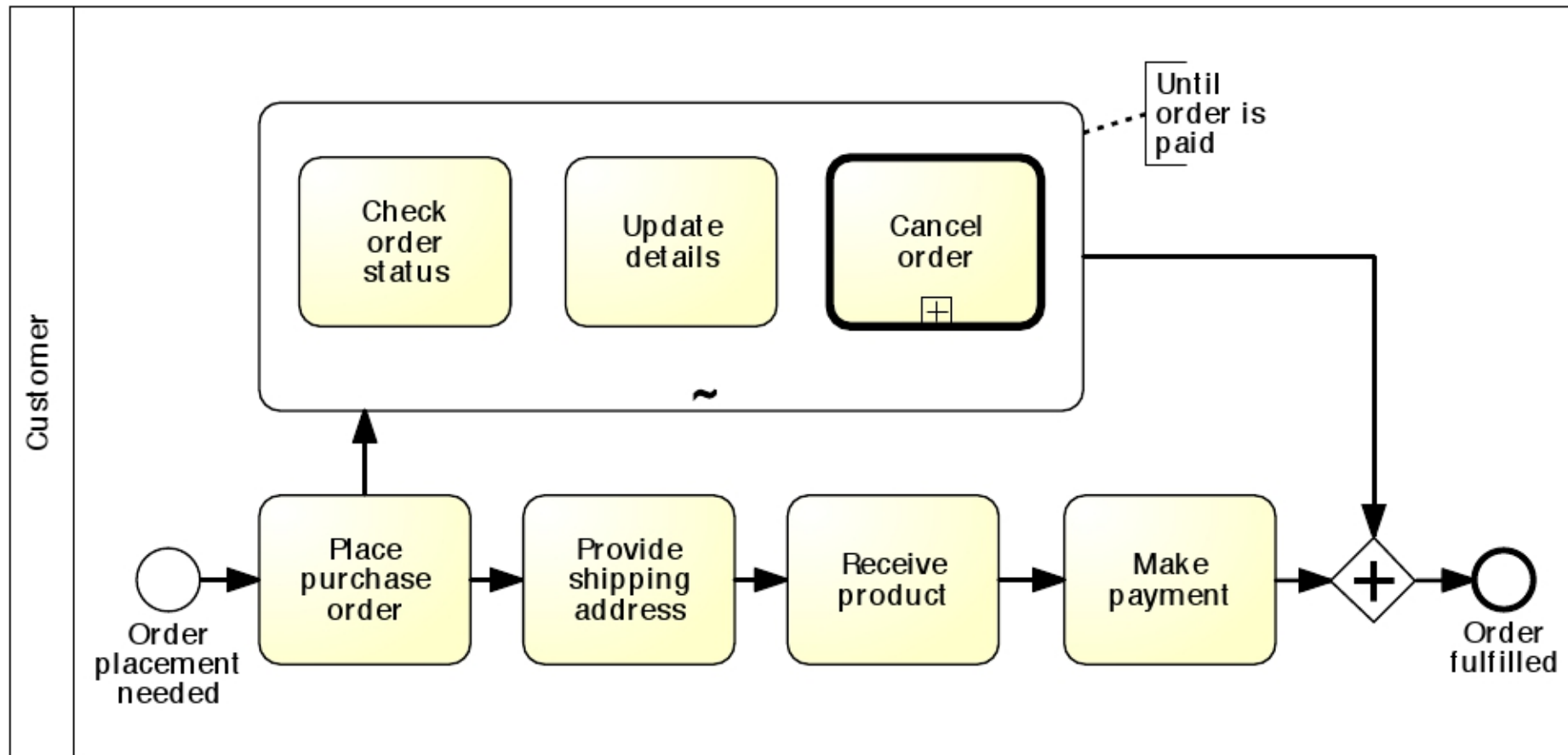

Exercise - Model the following process snippet

A typical army recruitment process starts by shortlisting all candidates' applications. Those shortlisted are then called to sit the following tests: drug and alcohol, eye, color vision, hearing, blood, urine, weight, fingerprinting and doctor examination. The color vision can only be done after the eye test, while the doctor examination can only be done after color vision, hearing, blood, urine and weight have been tested. Moreover, it may be required for some candidates to repeat some of these tests multiple times in order to get a correct assessment, e.g. the blood test may need to be repeated if the candidate has taken too much sugar in the previous 24 hours. The candidates that pass all tests are asked to sit a mental exam and a physical exam, followed by an interview. Only those that also pass these two exams and perform well in the interview can be recruited in the army.

Solution

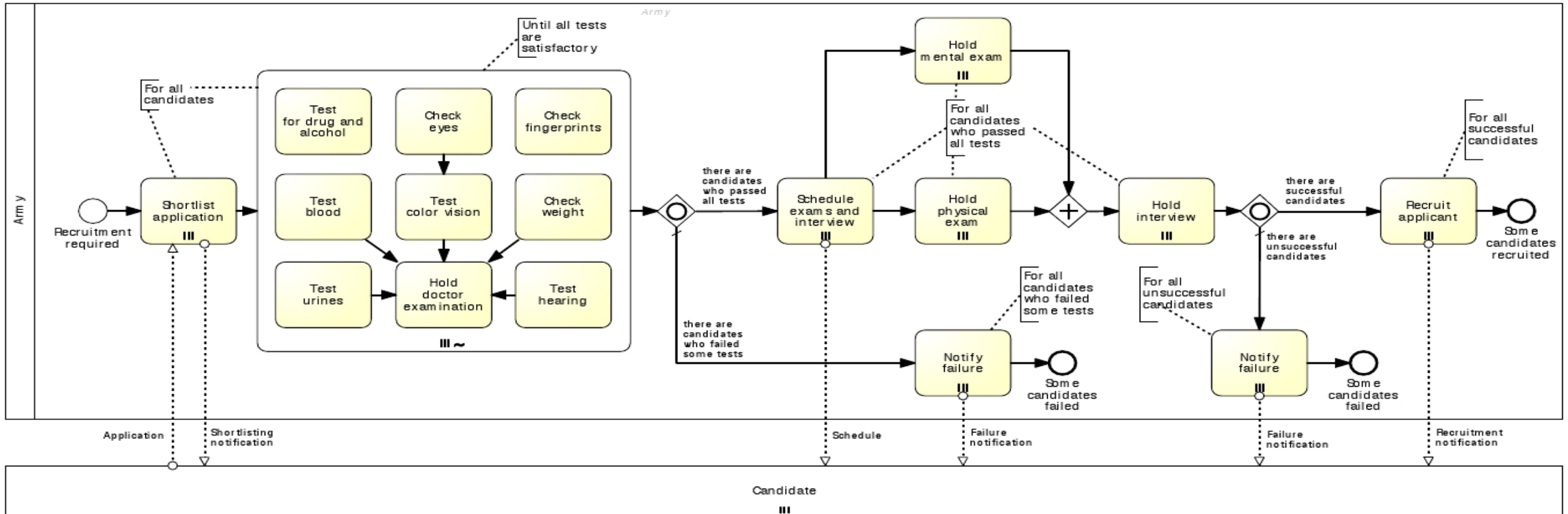

Types of gateways

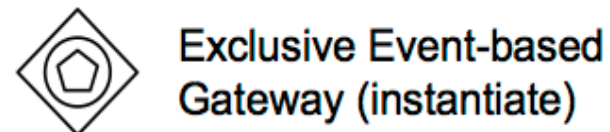
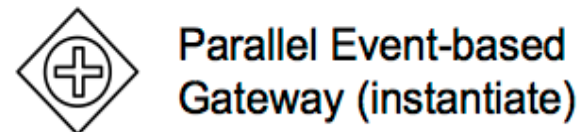
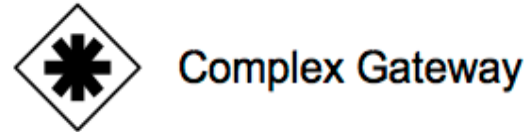
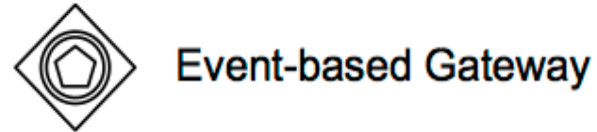
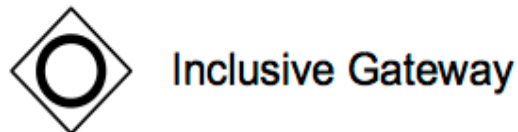
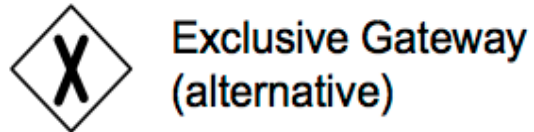

M. Weske: Business Process Management,
© Springer-Verlag Berlin Heidelberg 2012, 2007

Exclusive Gateways



Exclusive Gateway



Exclusive Gateway
(alternative)

- Indicates **locations within a business process where the sequence flow can take two or more alternative paths.**
- Only **one of the paths** can be taken.
- Depicted by a **diamond shape** that **may contain** a marker that is shaped like an “X”.
- We use a **XOR-join to merge** two or more alternative branches that may have previously been **forked with a XOR-split.**

Exclusive gateway with default flow

- Exclusive gateways are locations within a process where there are two or more alternative paths.
- The criteria for the decision, which the exclusive gateway represents, exist as conditions on each of the outgoing sequence flow.
- When a token arrives at an exclusive gateway, there is an immediate evaluation of the conditions that are on the gateway's outgoing sequence flow. One of those conditions must always evaluate to true.

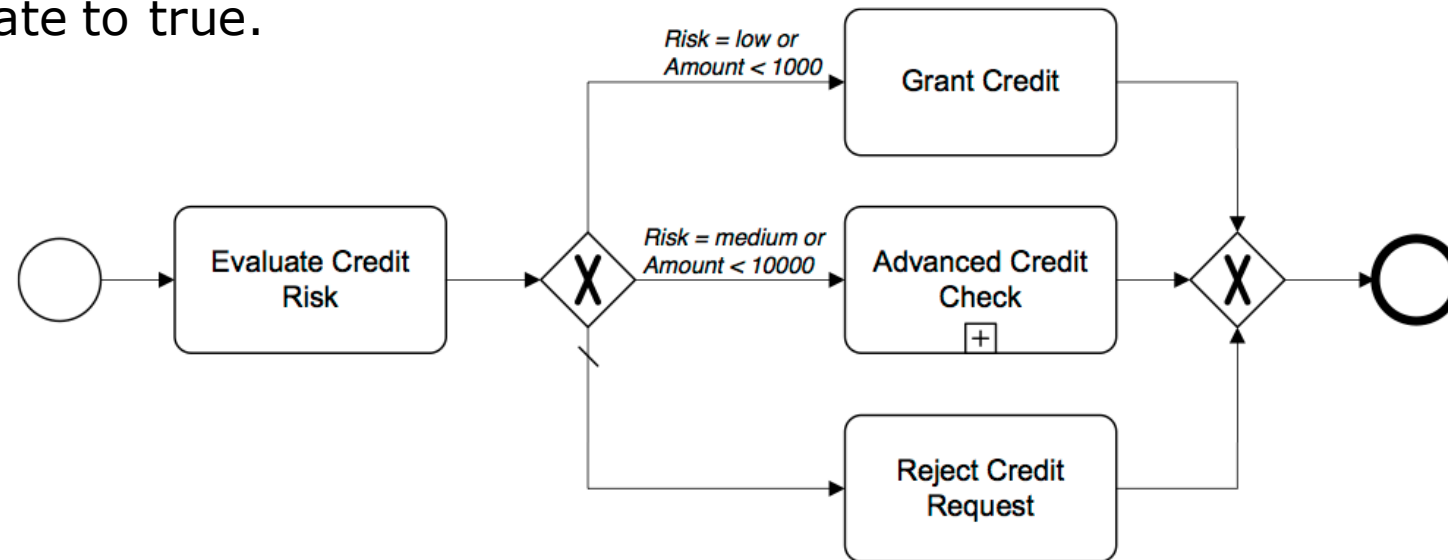

Exclusive gateway with default flow

- One way for the modeler to ensure that the process does not get stuck at an exclusive gateway is to use a default condition for one of the outgoing sequence flow.
- The default condition can complement a set of standard conditions to provide an automatic escape mechanism in case all the standard conditions evaluate to false.
- The default is chosen if all the other sequence flow conditions turn out to be false.

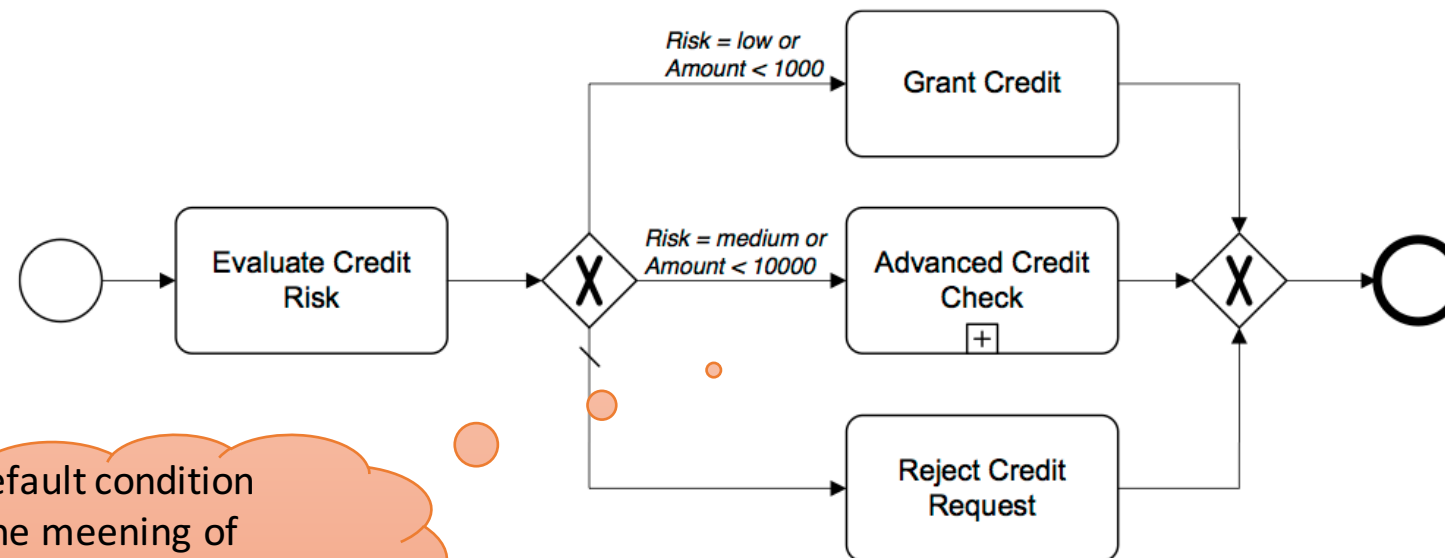

The default condition has the meaning of "otherwise" and it can be unlabeled

Exclusive gateway with default flow

- When a token arrives at the exclusive gateway, there is no evaluation of conditions (on the incoming sequence flow), and immediately moves down the outgoing sequence flow.

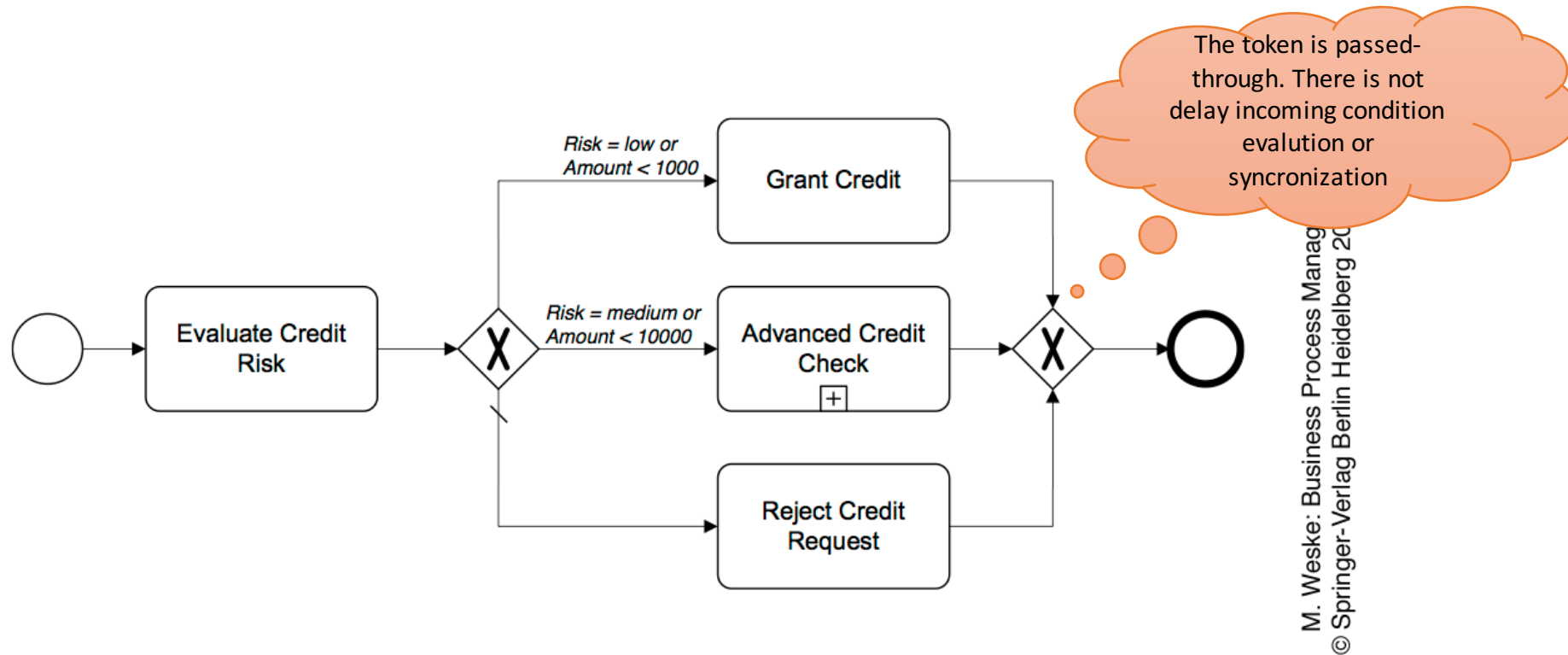

Exercise

- As soon as an invoice is received from a customer, it needs to be checked for mismatches.
- The check may result in either of these three options:
 - i) there are no mismatches, in which case the invoice is posted;
 - ii) there are mismatches but these can be corrected, in which case the invoice is re-sent to the customer; and
 - iii) there are mismatches but these cannot be corrected, in which case the invoice is blocked.
- Once one of these three activities is performed the invoice is parked and the process completes.

Solution

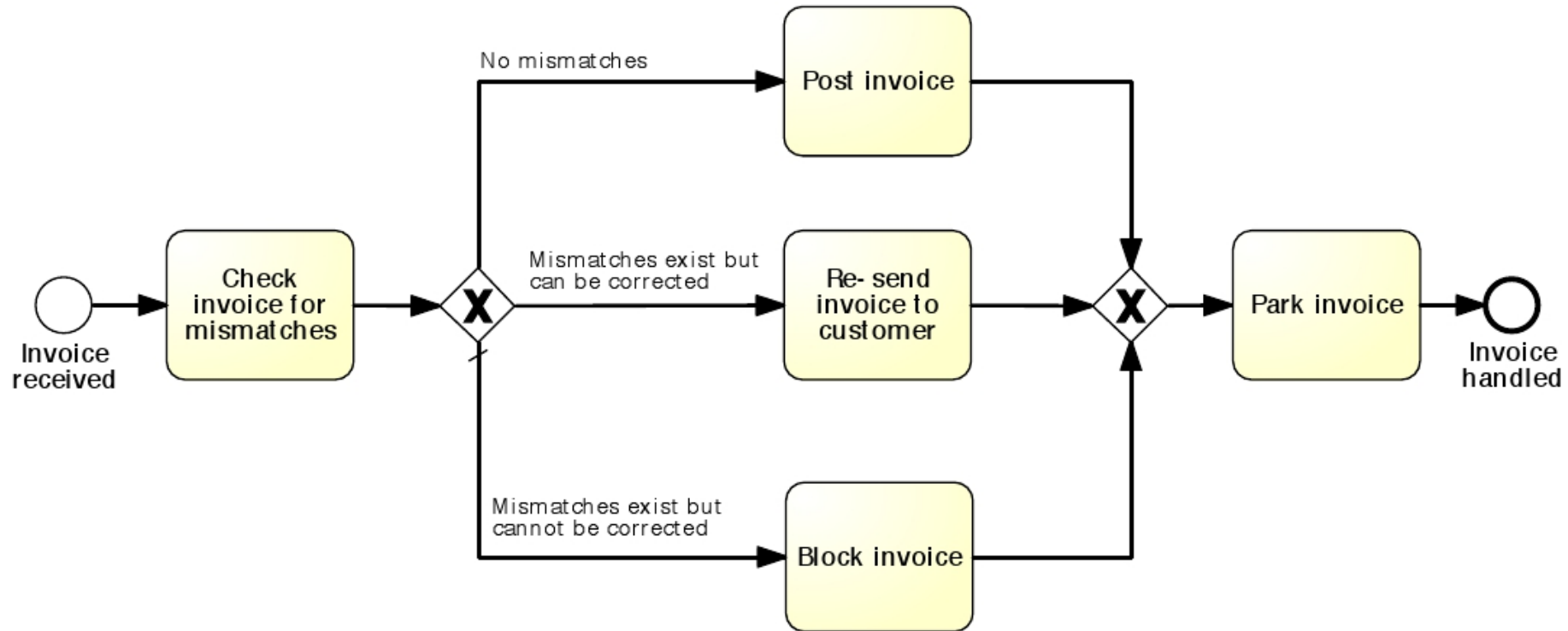

Exclusive gateways realizing a loop

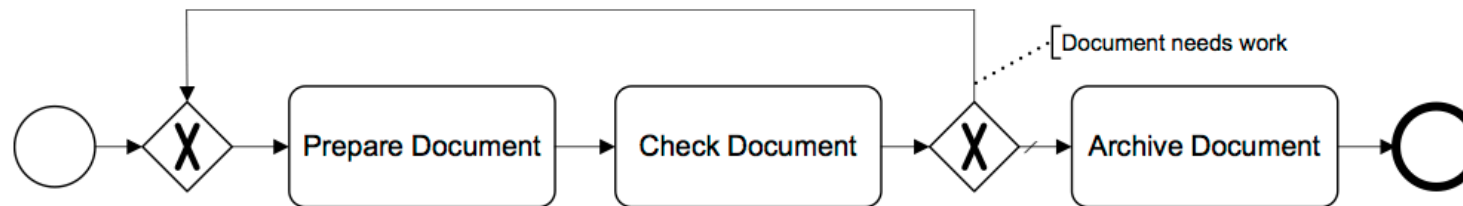

M. Weske: Business Process Management,
© Springer-Verlag Berlin Heidelberg 2012, 2007

BP with uncontrolled flow

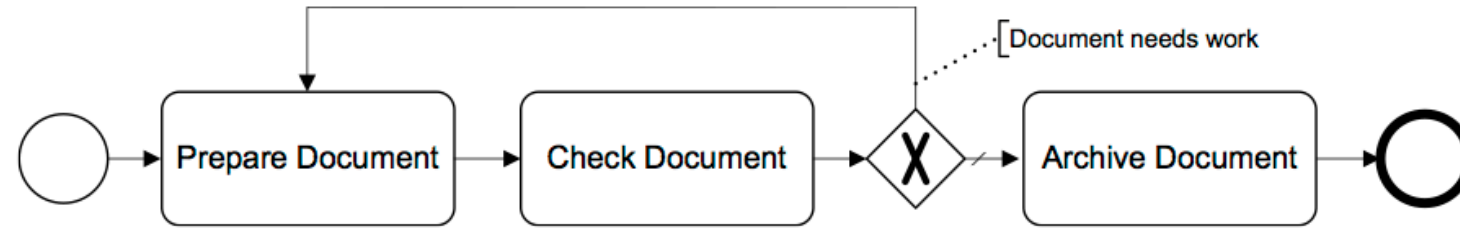

M. Weske: Business Process Management,
© Springer-Verlag Berlin Heidelberg 2012, 2007

BP with split and join activities - livelock

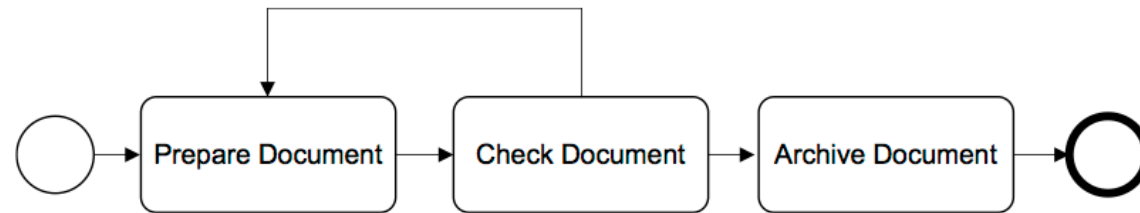

M. Weske: Business Process Management,
© Springer-Verlag Berlin Heidelberg 2012, 2007

Parallel Gateways

- Provide a mechanism to synchronize parallel flows (AND-join) and to create parallel flows (AND-split), with activities that can be executed concurrently.
- Depicted by a diamond shape that must contain a marker that is shaped like a plus sign.



Parallel Gateway

Parallel gateway (Splitting Behaviour)

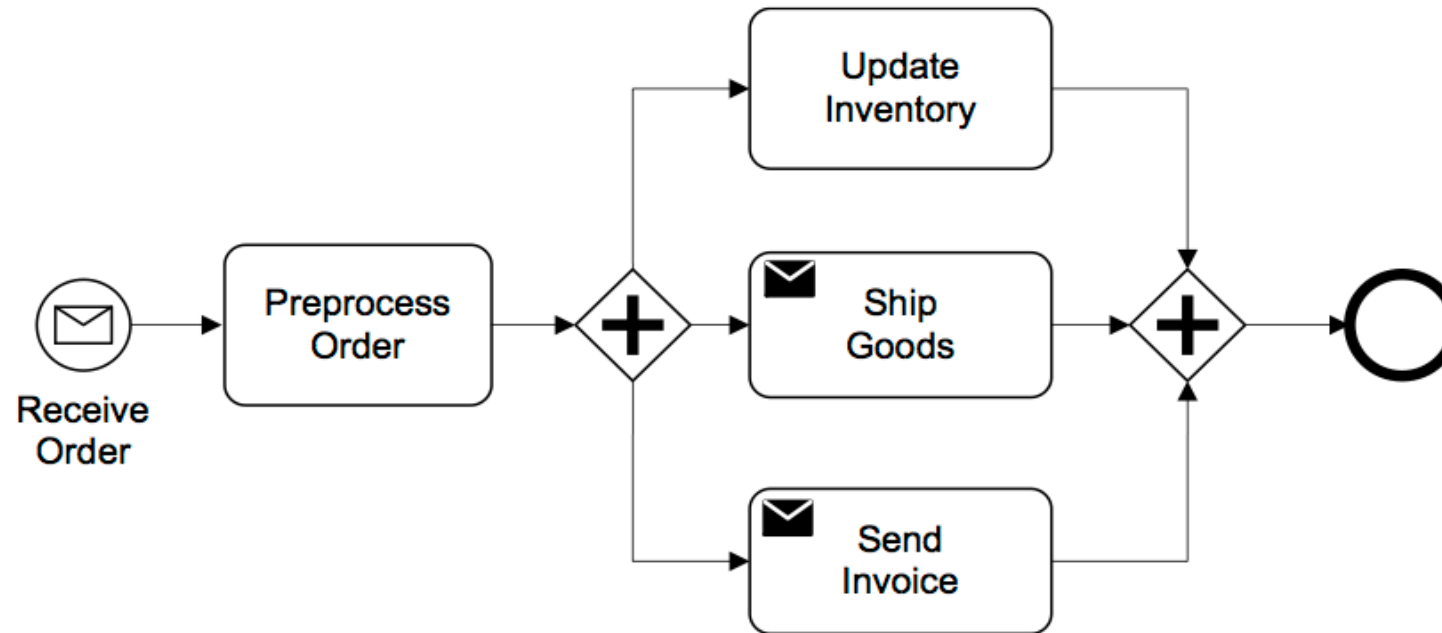

- When a token arrives at a parallel gateway, there is no evaluation of any conditions on the outgoing sequence flow.
- The parallel gateway will create parallel paths.
- This means that the gateway will create a number of tokens that are equal to the number of outgoing sequence flow. One token moves down each of those outgoing sequence flow.

Parallel gateway (Merging Behaviour)

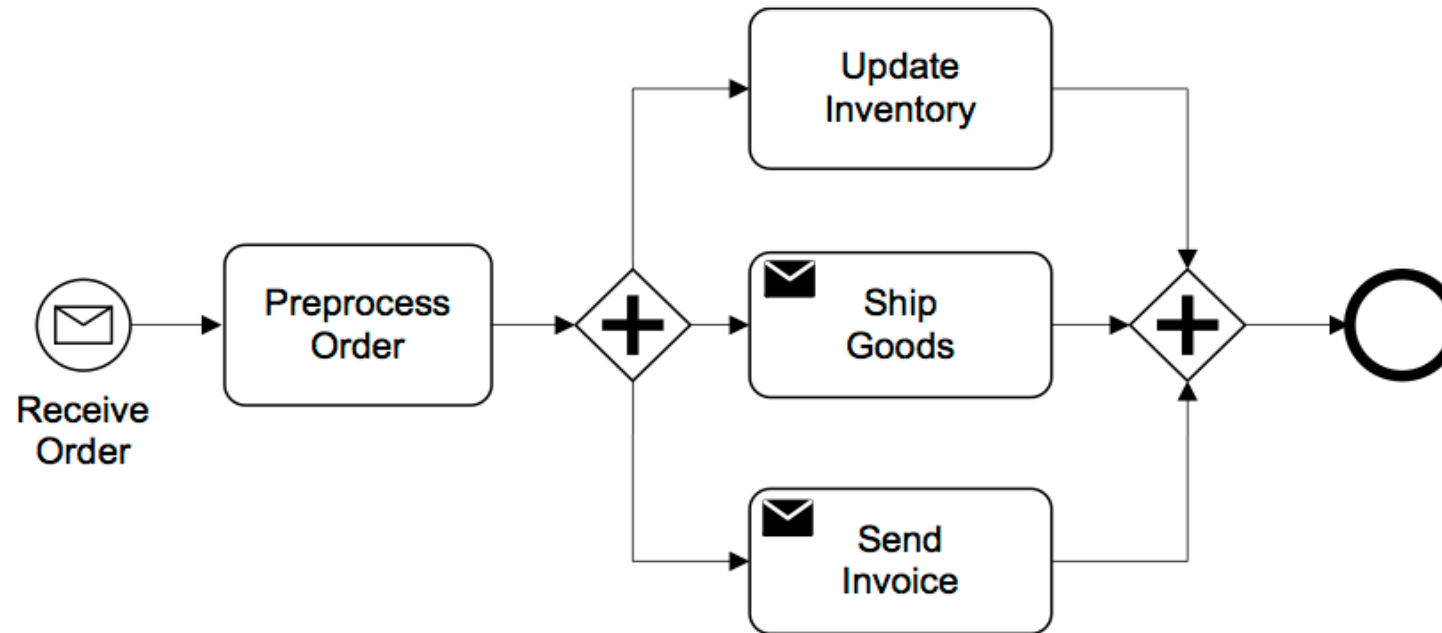

- To synchronize the flow, the parallel gateway will wait for a token to arrive from each incoming sequence flow.
- When the first token arrives, there is no evaluation of a condition for the incoming sequence flow, but the token is “held” at the gateway and does not continue.
- When all the tokens are arrived, then they are merged and one token moves down the outgoing sequence flow.

Exercise

- Once the boarding pass has been received, passengers proceed to the security check. Here they need to pass the personal security screening and the luggage screening. Afterwards, they can proceed to the departure level.

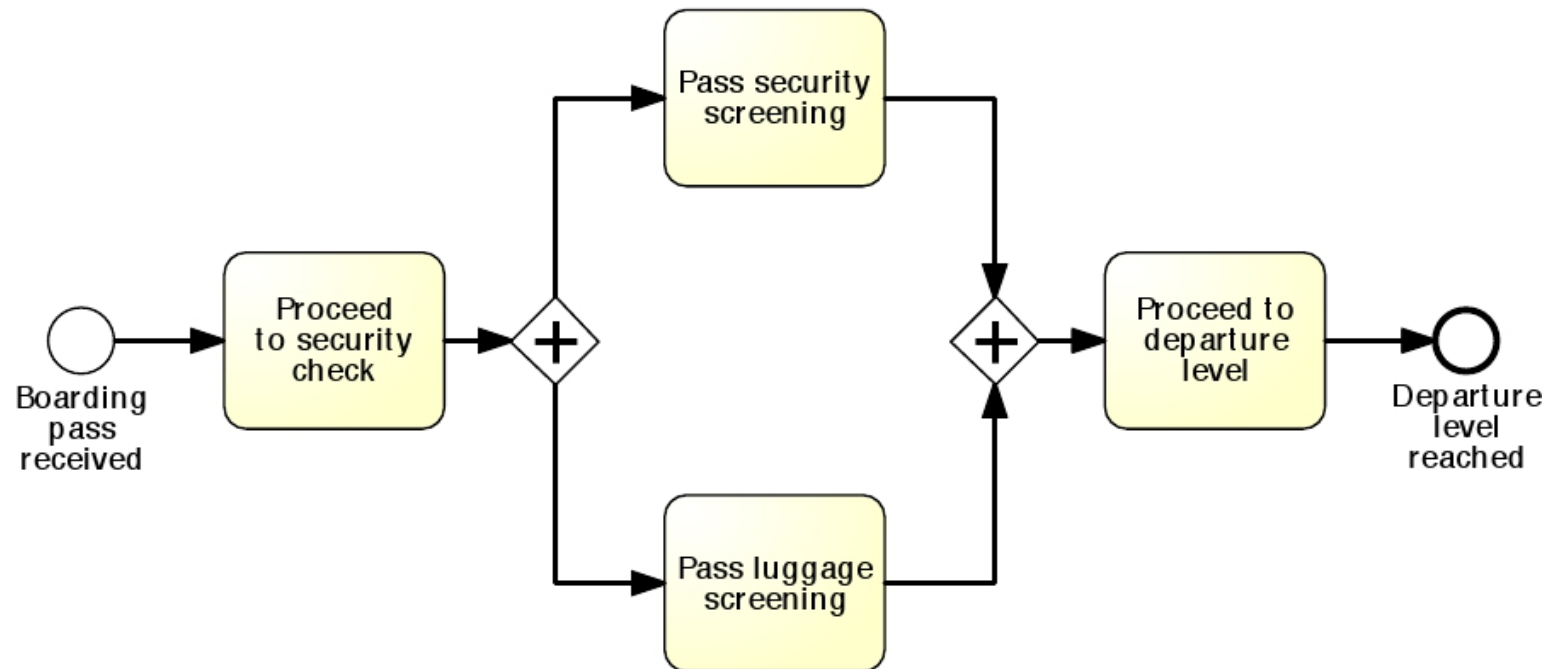

Gateways Combination

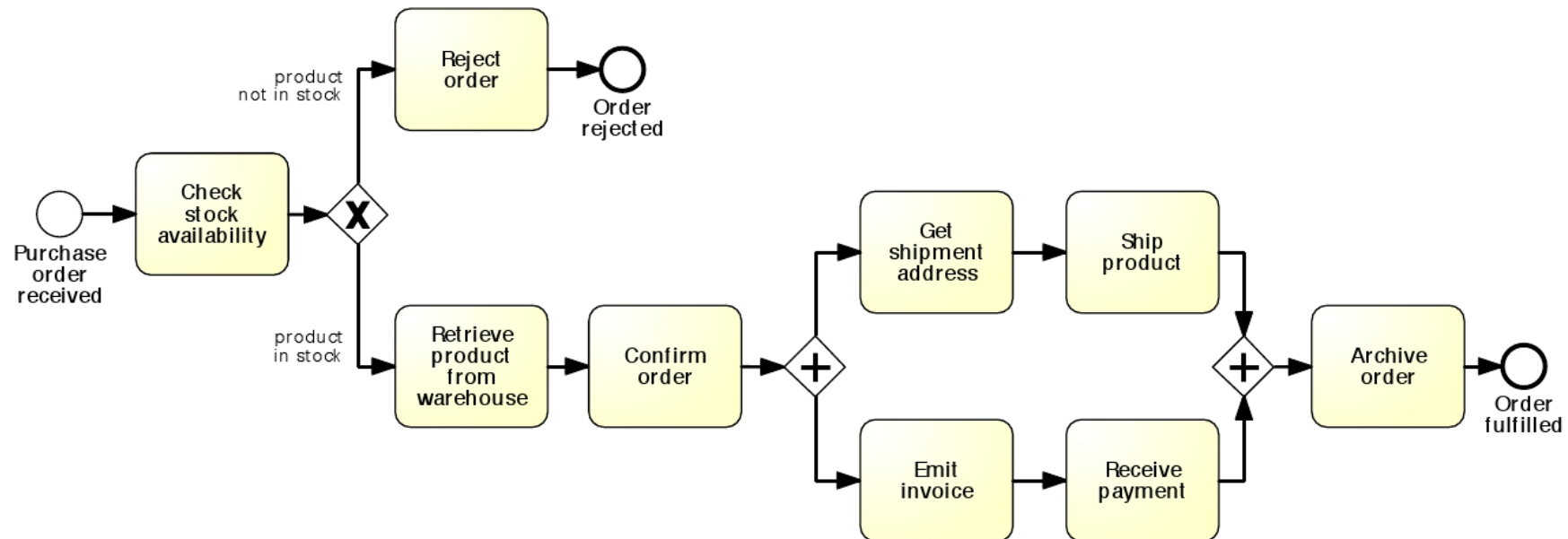

Inclusive Gateways

- Sometimes we may need to take one or more branches after a decision activity.
- To model situations where a decision may lead to one or more options being taken at the same time, we need to use an inclusive (OR) split gateway.
- An OR-split is similar to the XOR-split, but the conditions on its outgoing branches do not need to be mutually exclusive, i.e. more than one of them can be true at the same time.
- When we encounter an OR-split, we thus take one or more branches depending on which conditions are true.



Inclusive Gateway

Inclusive or gateway (Splitting Behaviour)

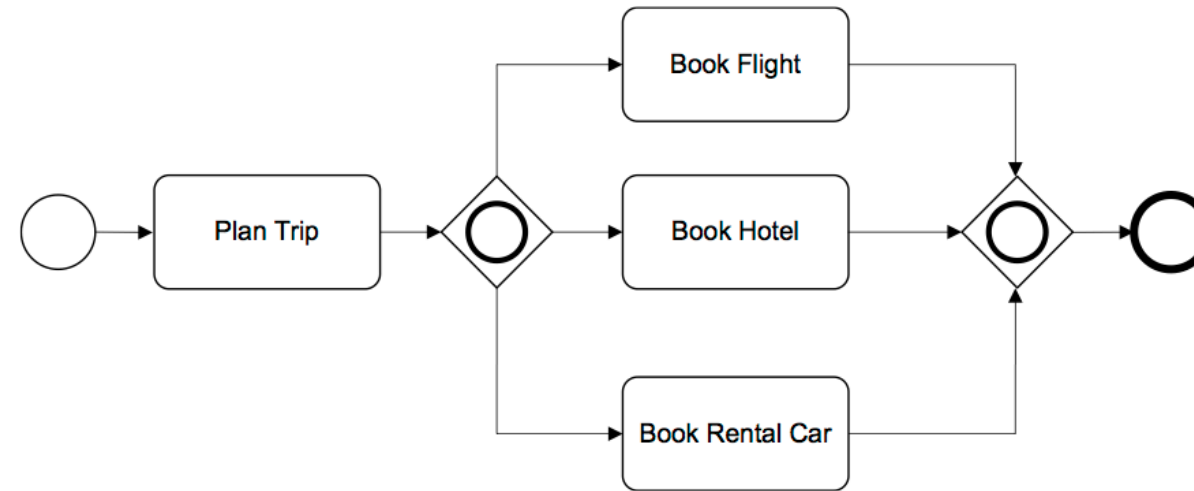

M. Weske: Business Process Management,
© Springer-Verlag Berlin Heidelberg 2012, 2007

- Inclusive gateways support decisions where more than one outcome is possible at the decision point.
- Inclusive gateway with multiple outgoing sequence flows creates one or more paths based on the conditions on those sequence flow.
- In terms of token semantics, this means that the OR-split takes the input token and generates a number of tokens equivalent to the number of output conditions that are true.
- Every condition that evaluates to true will result in a token moving down that sequence flow.
- At least one of those conditions must evaluate to true.

Inclusive or gateway (Merging Behaviour)

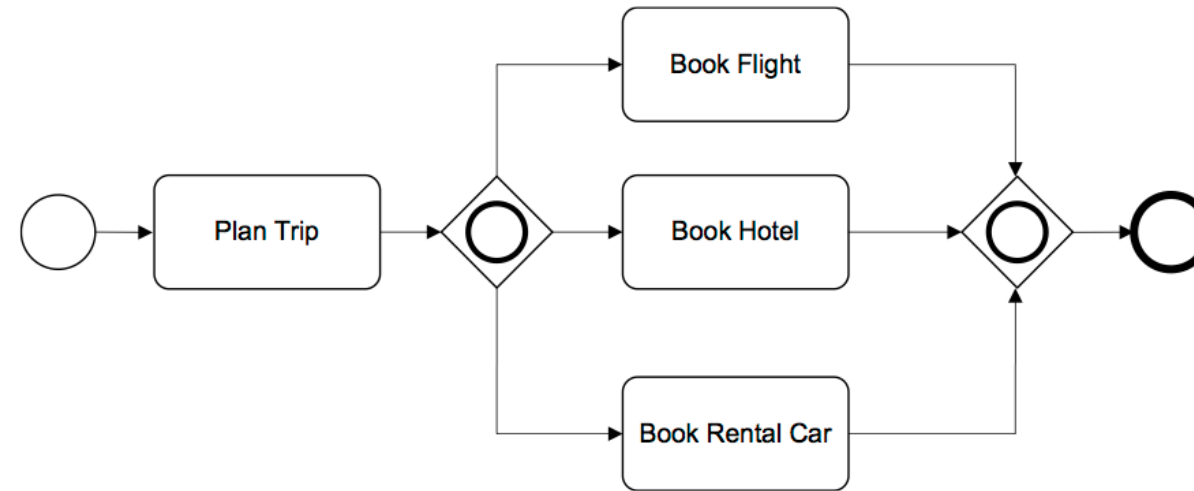

M. Weske: Business Process Management,
© Springer-Verlag Berlin Heidelberg 2012, 2007

- When the first token arrives at the gateway, the gateway will “look” upstream for each of the other incoming sequence flow to see if there is a token that might arrive at a later time.
- Thus, the gateway will hold the first token that arrived in the upper path until the other token from the lower path arrives.
- When all the expected tokens have arrived at the gateway, the process flow is synchronized (the incoming tokens are merged) and then a token moves down the gateway’s outgoing sequence flow.

From BPMN 2.0 Specification to Process Execution

The Inclusive Gateway is activated if:

- At least one incoming Sequence Flow has at least one token and
- For every directed path formed by Sequence Flow that:
 - i. starts with a Sequence Flow f of the diagram that has a token,
 - ii. ends with an incoming Sequence Flow of the inclusive gateway that has no token,
 - iii. does not visit the Inclusive Gateway.
- There is also a directed path formed by Sequence Flow that:
 - i. starts with f ,
 - ii. ends with an incoming Sequence Flow of the inclusive gateway that has a token,
 - iii. does not visit the Inclusive Gateway.

EXAMPLE

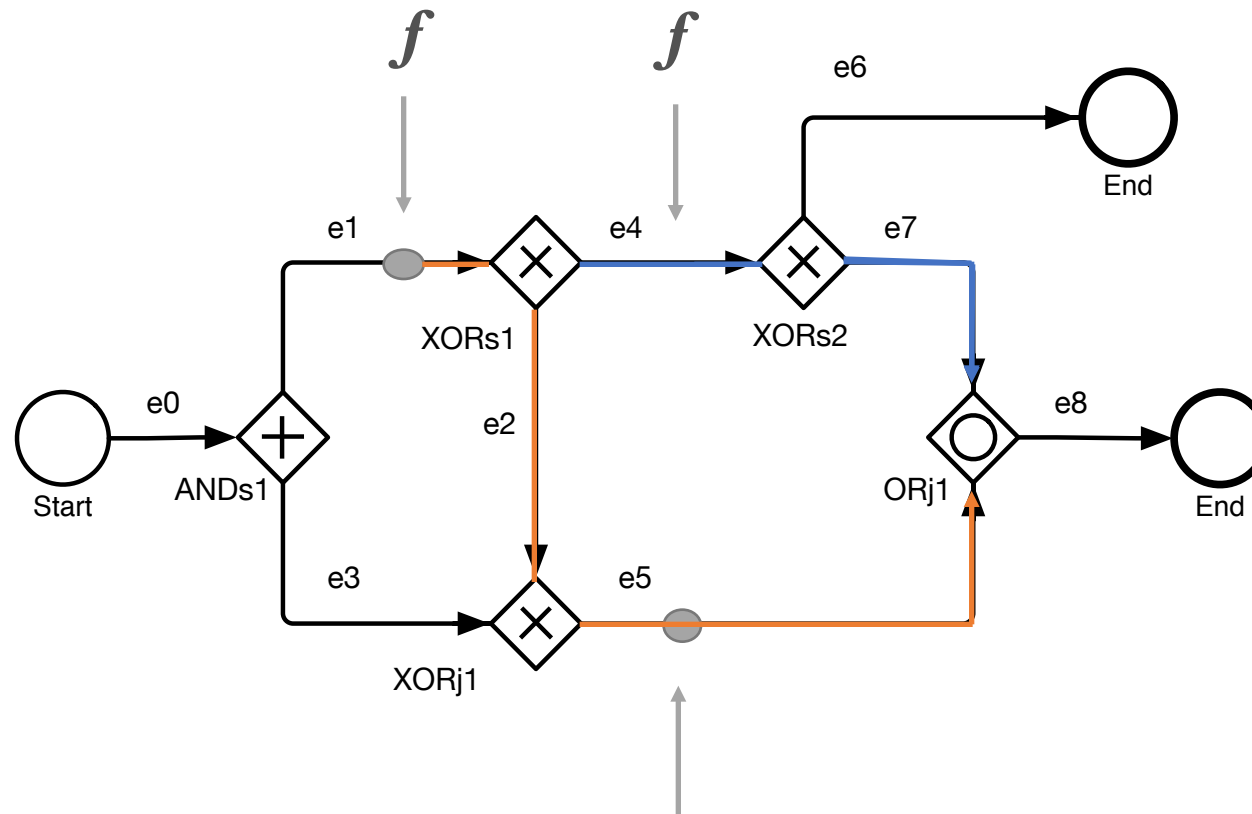

incoming Sequence Flow has at least one token

An Example of Deadlock Upstream an OR-Join

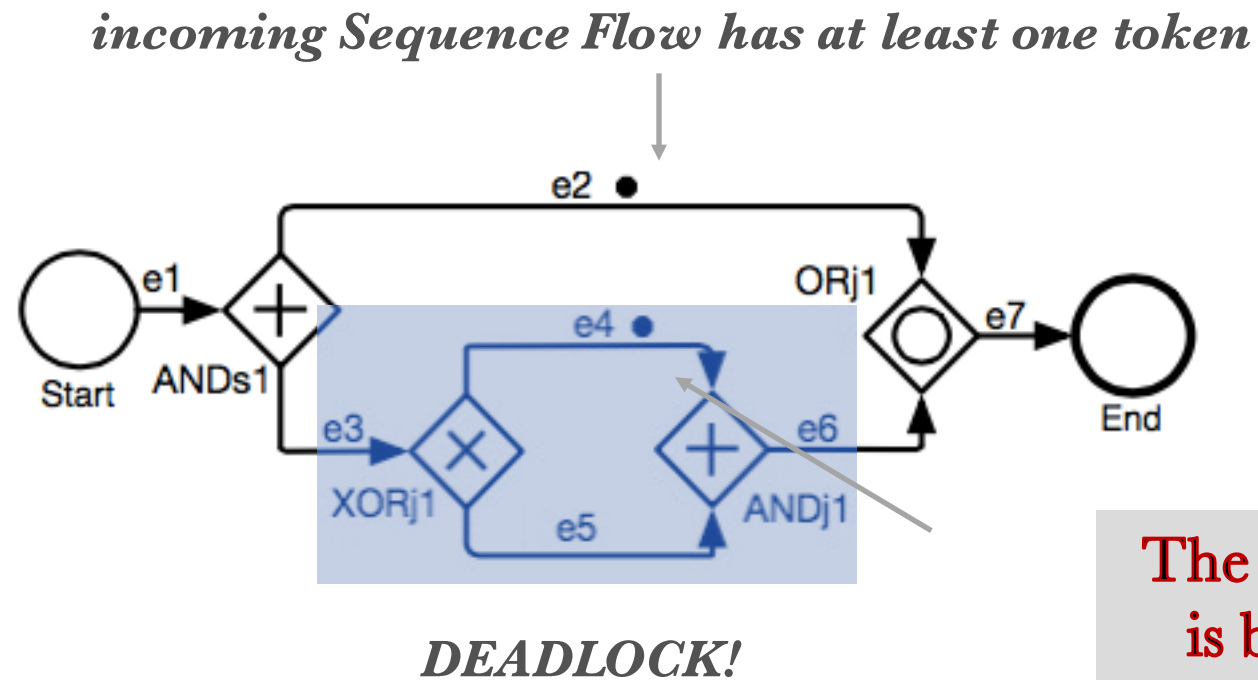

An Example of Vicious Circle

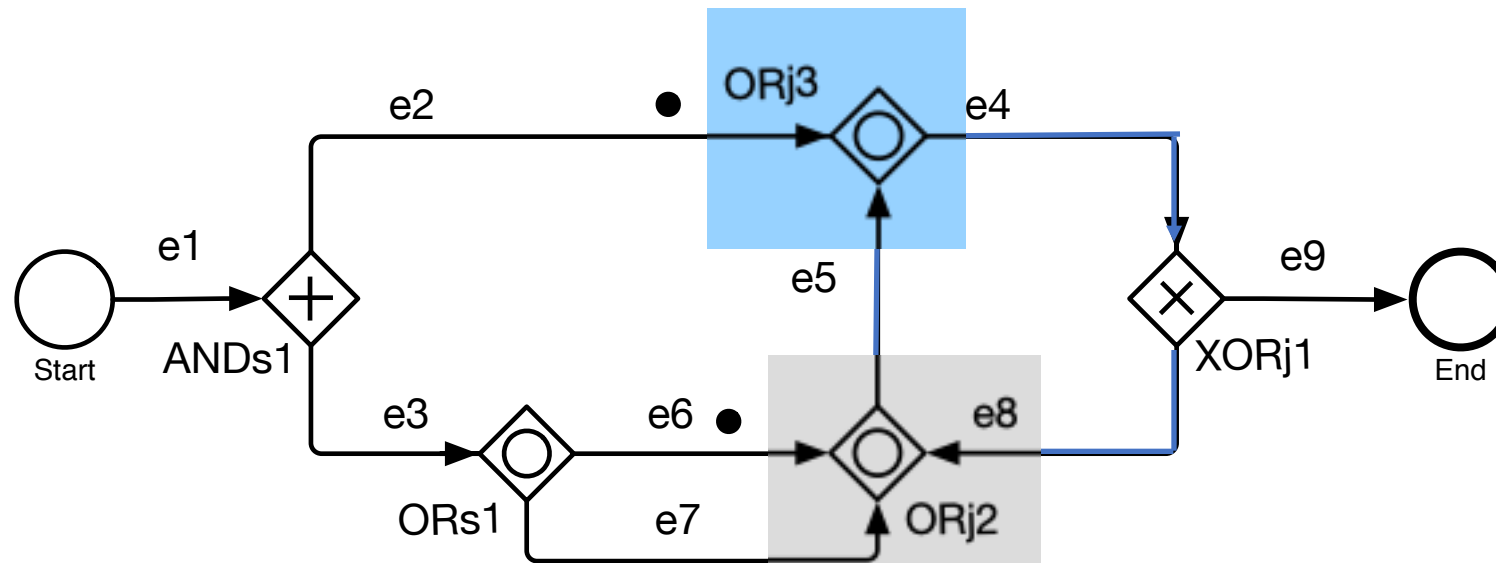

**The OR-Join
is blocked**

Exercise

- A company has two warehouses that store different products: Amsterdam and Hamburg.
- When an order is received, it is distributed across these warehouses: if some of the relevant products are maintained in Amsterdam, a sub-order is sent there; likewise, if some relevant products are maintained in Hamburg, a sub-order is sent there.
- Afterwards, the order is registered and the process completes.

A first solution

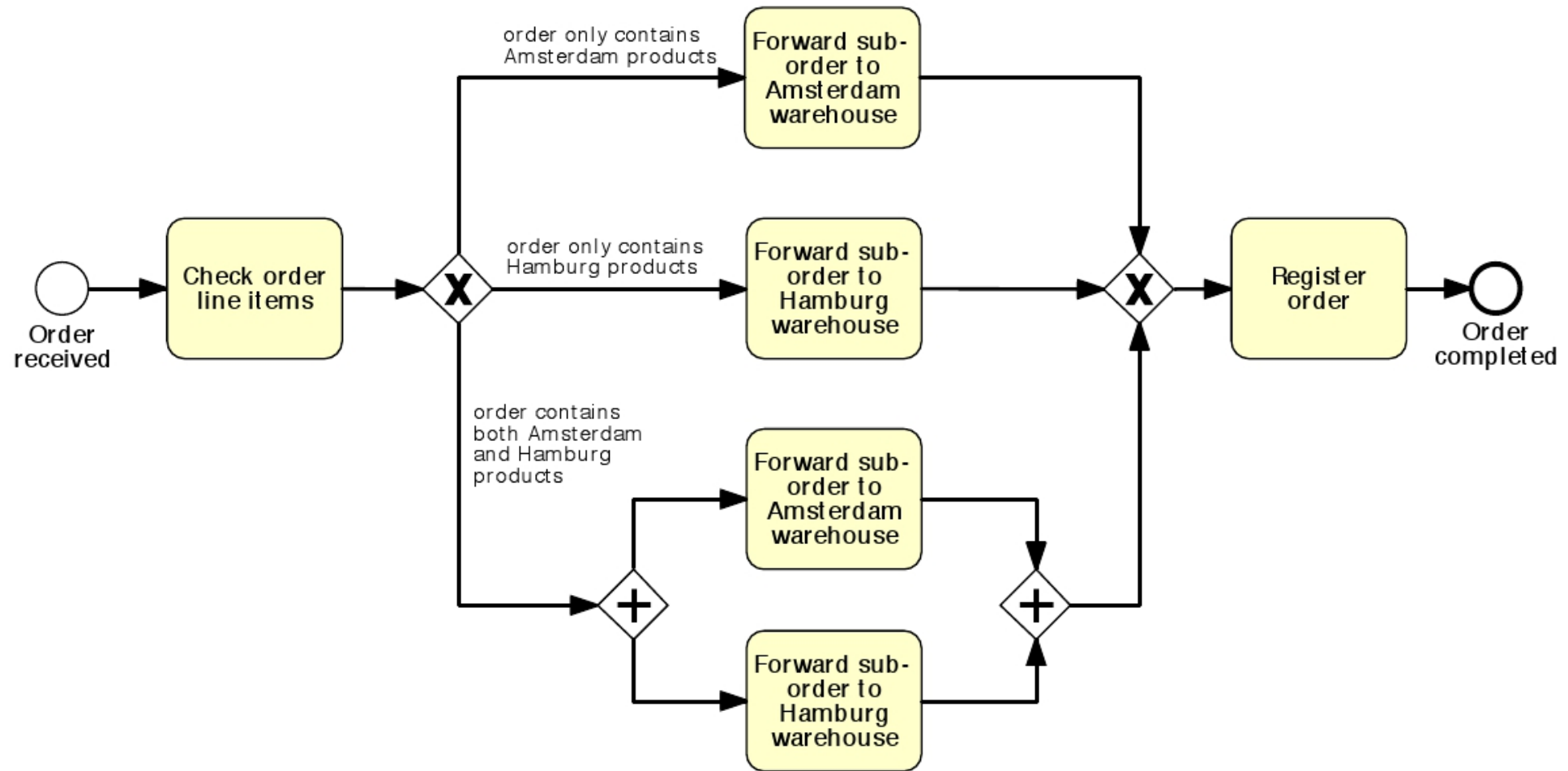

A second solution

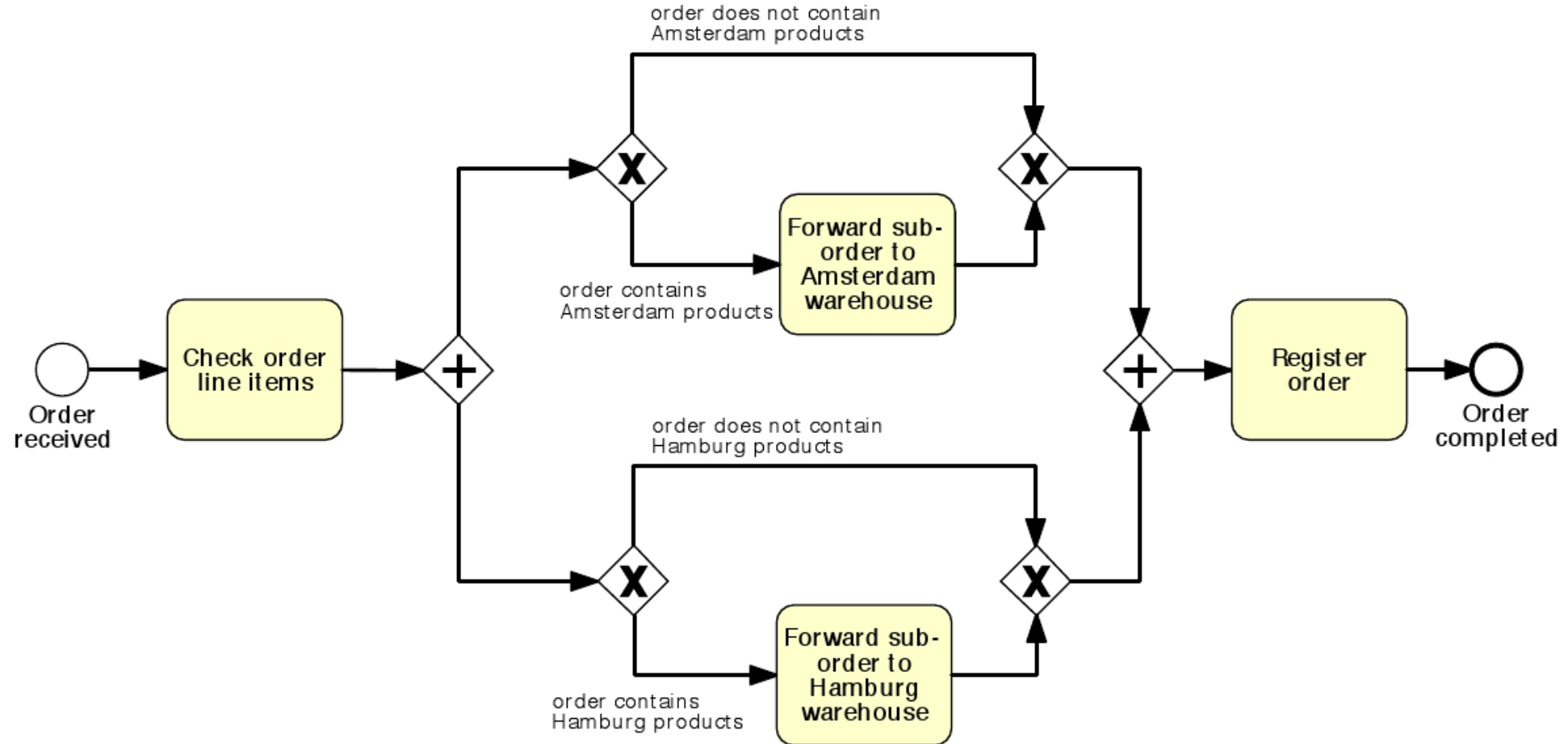

A third solution with OR gateways

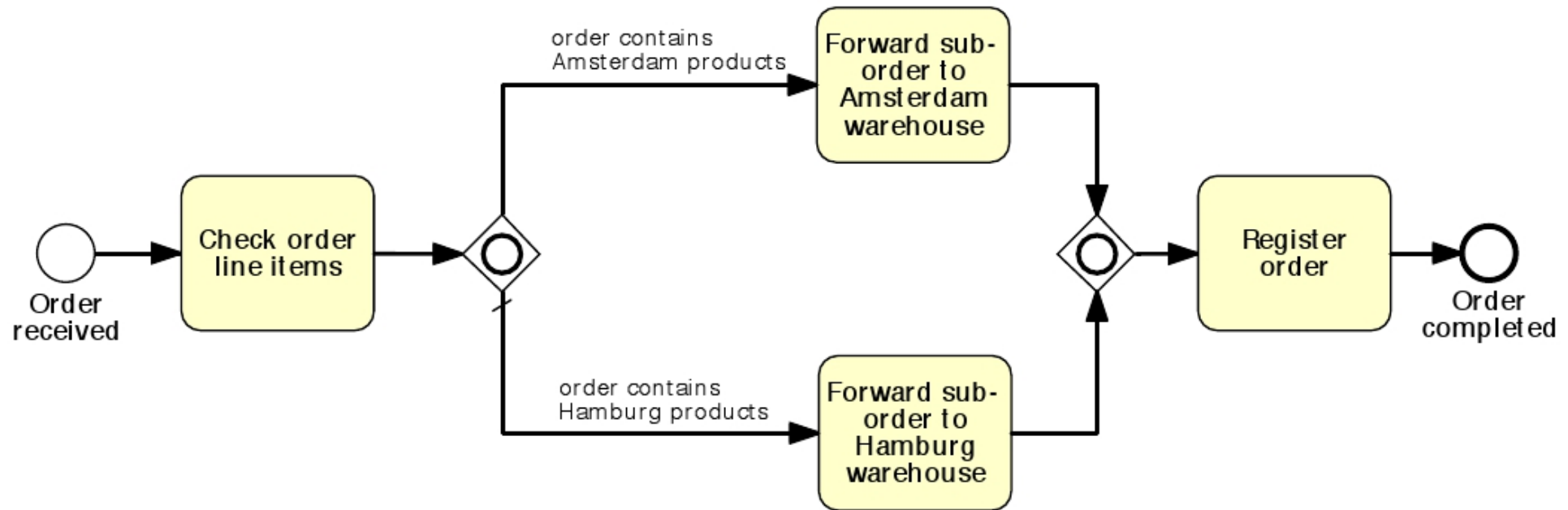

What type should we assign to this join?

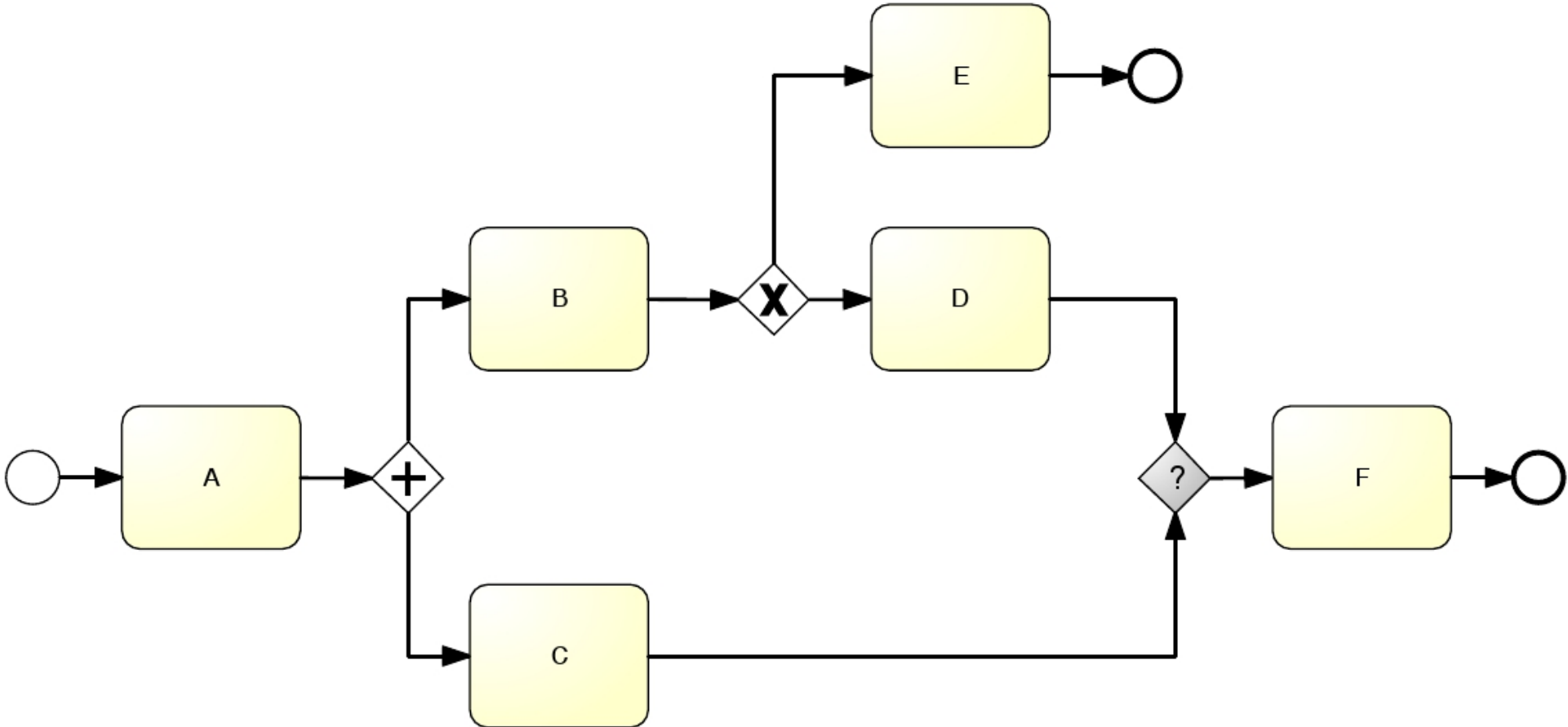

Solution

- Since the OR-join semantics is not simple, the presence of this element in a model may confuse the reader.
- Thus, we suggest to use it only when it is strictly required.
- Clearly, it is easy to see that an OR-join must be used whenever we need to synchronize control from a preceding OR-split. Similarly, we should use an AND-join to synchronize control from a preceding AND-split and an XOR-join to merge a set of branches that are mutually exclusive.

Handling BPMN Events

	Start Events		Intermediate Events				End Events	
	Catching	Catching	Boundary Interrupting, Catching	Boundary Non-Interrupting, Catching	Throwing	Throwing		
None or blanco: Untyped events, indicate start point, state changes or final states.								
Message: Receiving and sending messages.								
Timer: Cyclic timer events, points in time, time spans or timeouts.								
Escalation: Escalating to a higher level of responsibility.								
Conditional: Reacting to changed business conditions or integrating business rules.								
Link: Off-page connectors. Two corresponding link events equal a sequence flow.								
Error: Catching or throwing named errors.								
Cancel: Reacting to cancelled transactions or triggering cancellation.								
Compensation: Handling or triggering compensation.								
Signal: Signalling across different processes. A signal thrown can be caught multiple times.								
Multiple: Catching one out of a set of events. Throwing all events defined.								
Parallel Multiple: Catching all out of a set of parallel events.								
Terminate: Triggering the immediate termination of a process.								

M. Weske: Business Process Management,
© Springer-Verlag Berlin Heidelberg 2012, 2007

- While it comes natural to give a name (also called *label*) to each activity, we should not forget to give labels to events as well.
- For example, giving a name to each start event allows us to communicate what triggers an instance of the process, meaning, when should a new instance of the process be started.
- Similarly, giving a label to each end event allows us to communicate what conditions hold when an instance of the process completes, i.e. what the outcome of the process is.

More on Events

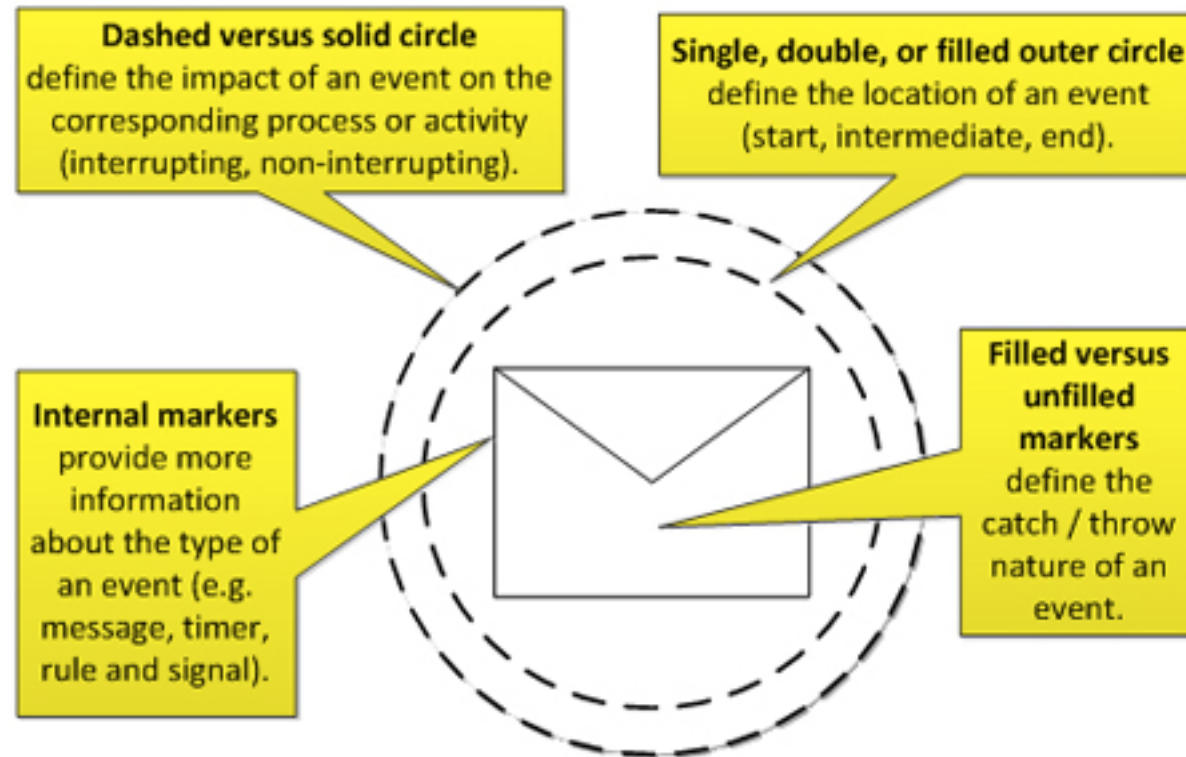

BPMN Events

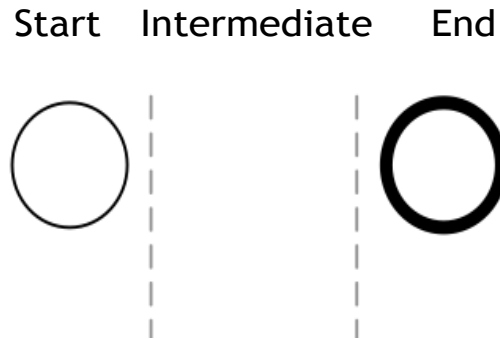

Untyped Event – Indicates that an instance of the process is created (start) or completed (end), without specifying the cause for creation/completion

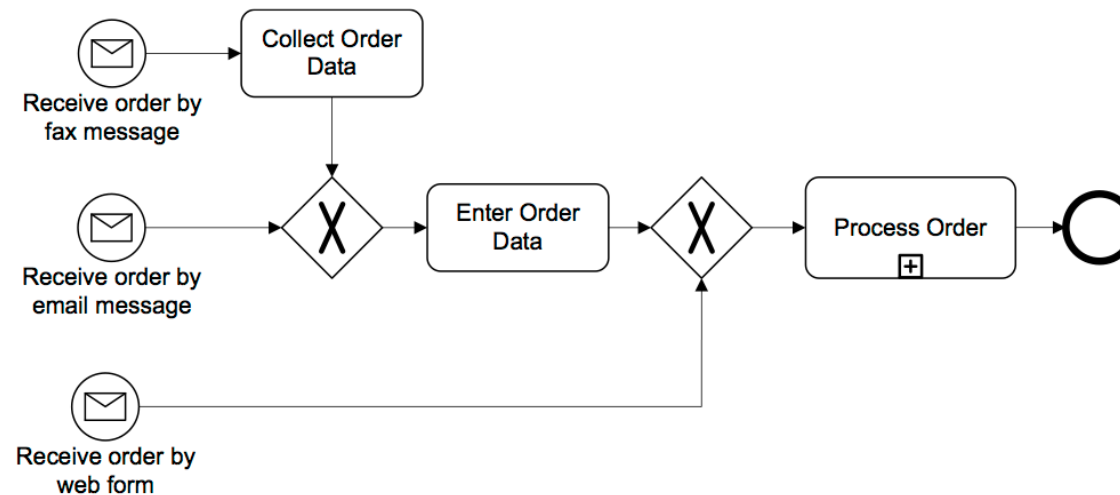

M. Weske: Business Process Management,
© Springer-Verlag Berlin Heidelberg 2012, 2007

Start Event Gateways

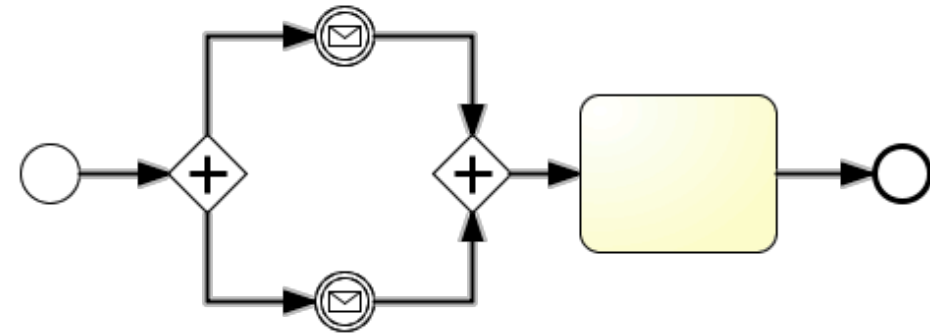
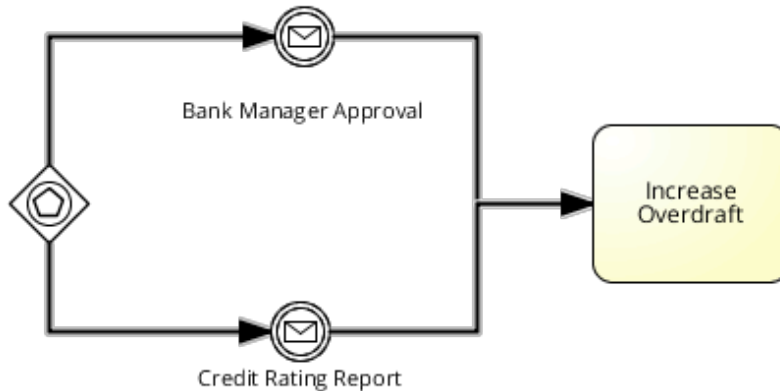
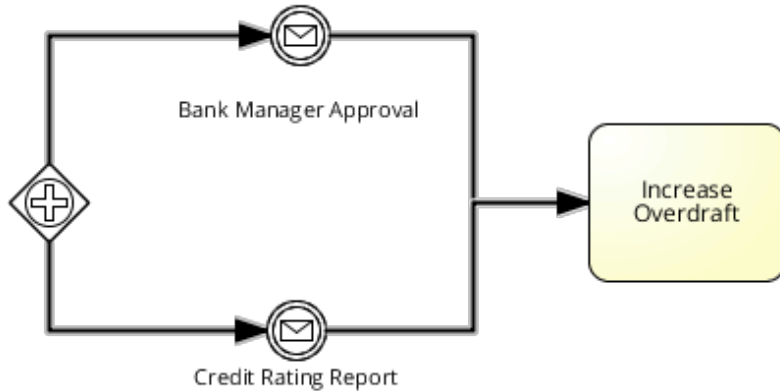

Parallel Event-based Gateway (instantiate)



Exclusive Event-based Gateway (instantiate)

Message Events

Start Intermediate End



Start Message Event – Indicates that an instance of the process is created when a message is **received**



End Message Event – Indicates that an instance of the process is completed when a message is **sent**



Intermediate Message Event – Indicates that an event is expected to occur during the process. The event is triggered when a message is **received** or **sent**



BPMN Events

Start Intermediate End



Start Timer Event – Indicates that an instance of the process is created at certain date(s)/time(s), e.g. start process at 6pm every Friday

Intermediate Timer Event – Triggered at certain date(s)/time(s), or after a time interval has elapsed since the moment the event is “enabled” (delay)

Message Events: Throwing and Catching Events

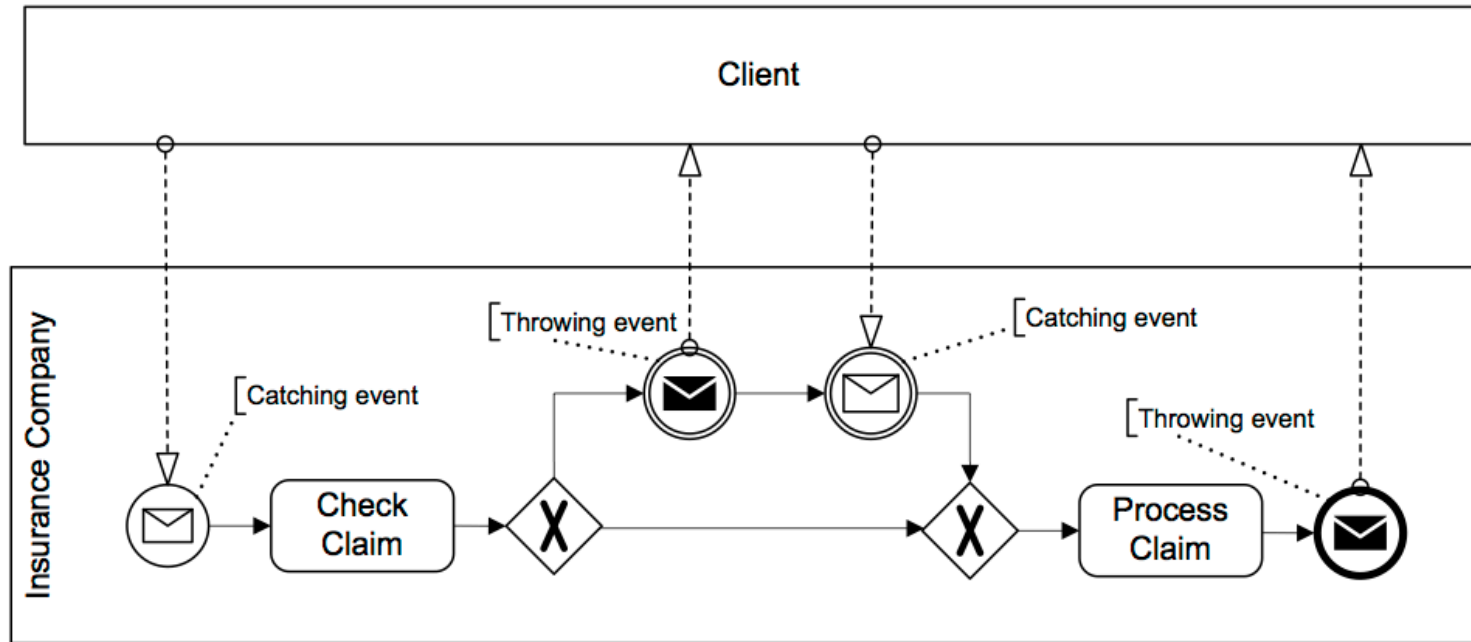

M. Weske: Business Process Management,
© Springer-Verlag Berlin Heidelberg 2012, 2007

Comparison with sending/receiving tasks

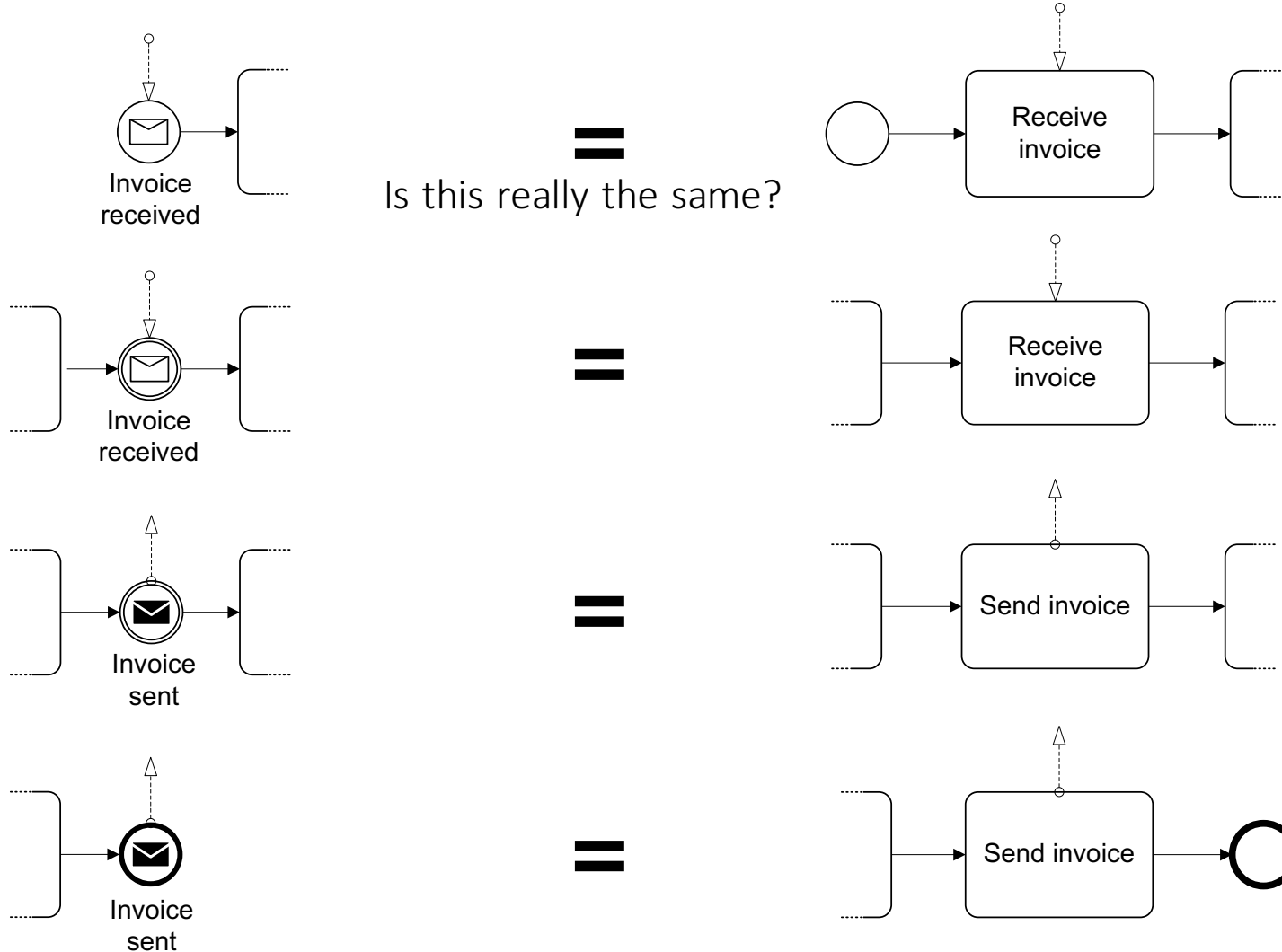

When to use what?

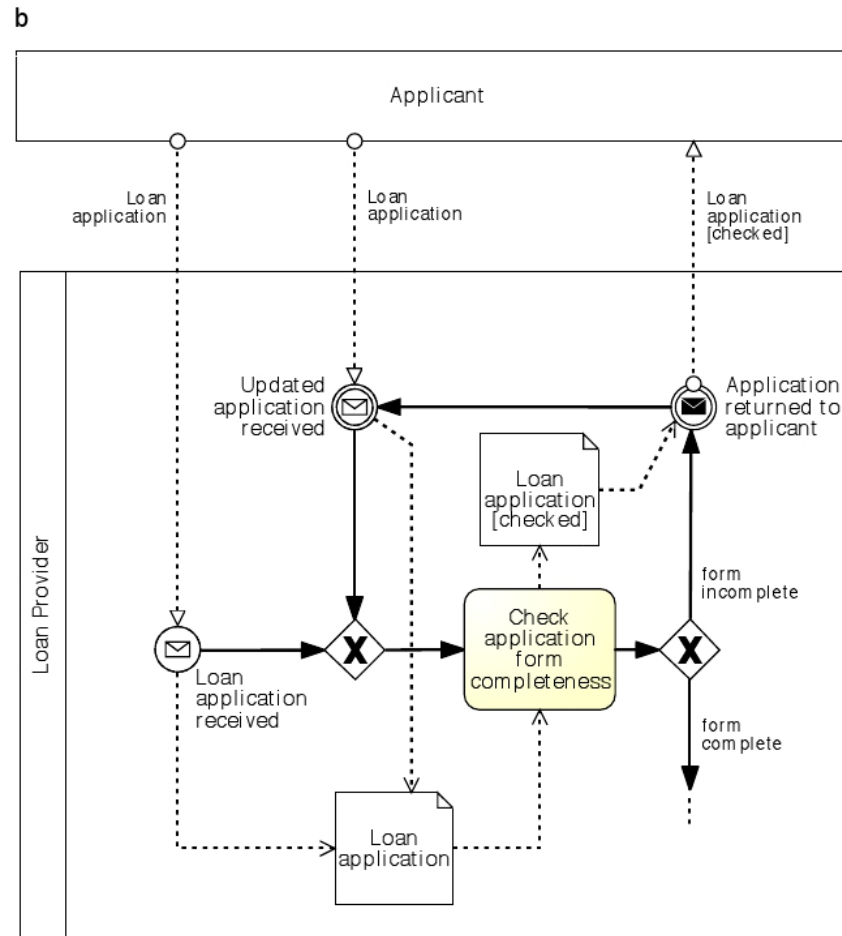
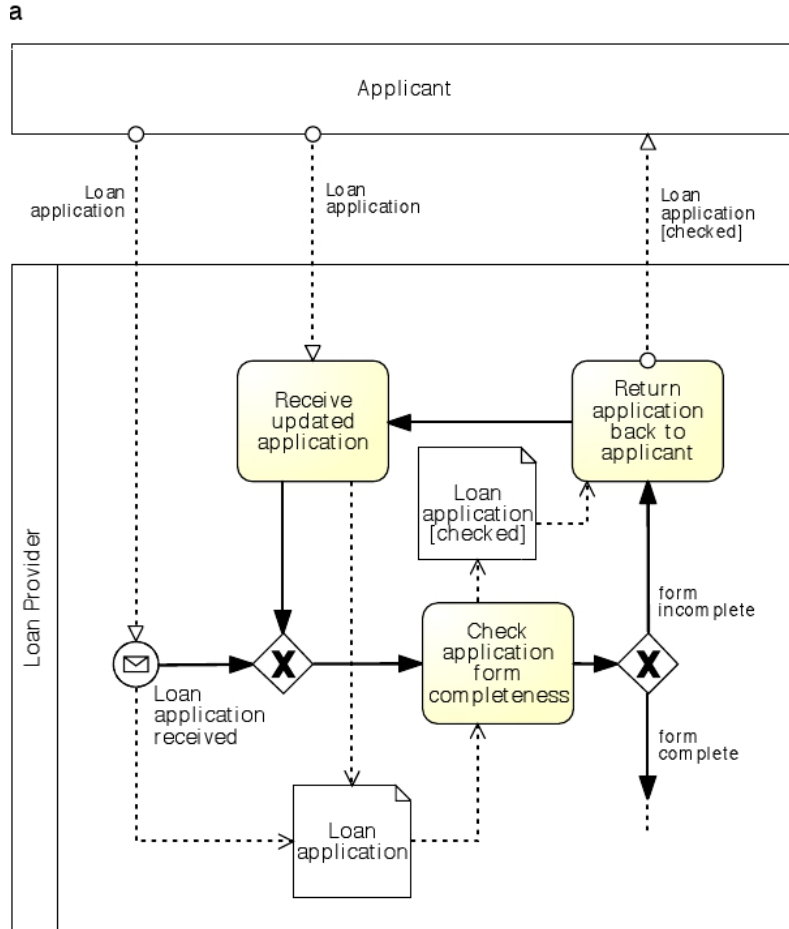

Use message events only when the corresponding activity would simply send or receive a message and do nothing else

Temporal Event and Example

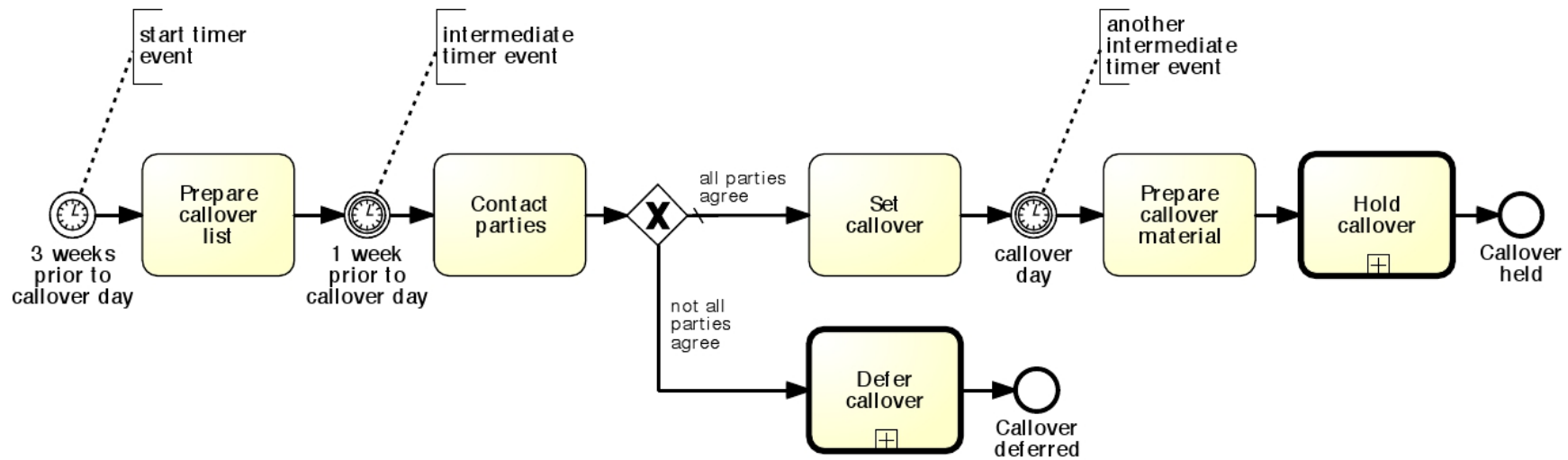

Modelling Exceptional Behaviours

(external)

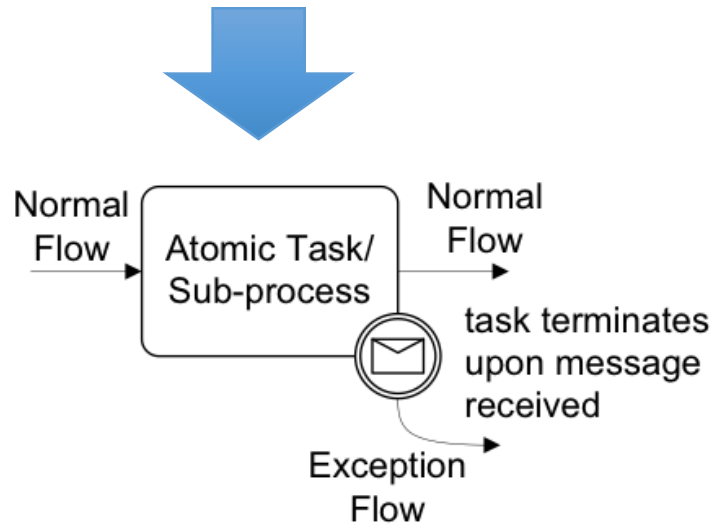

(time dependent)

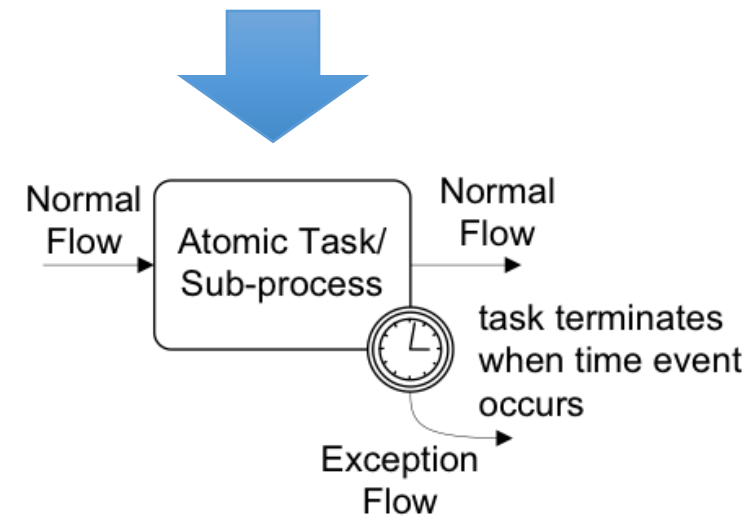

Both of them can be interrupting or not interrupting

??? (internal) ???

BP with interrupting boundary event

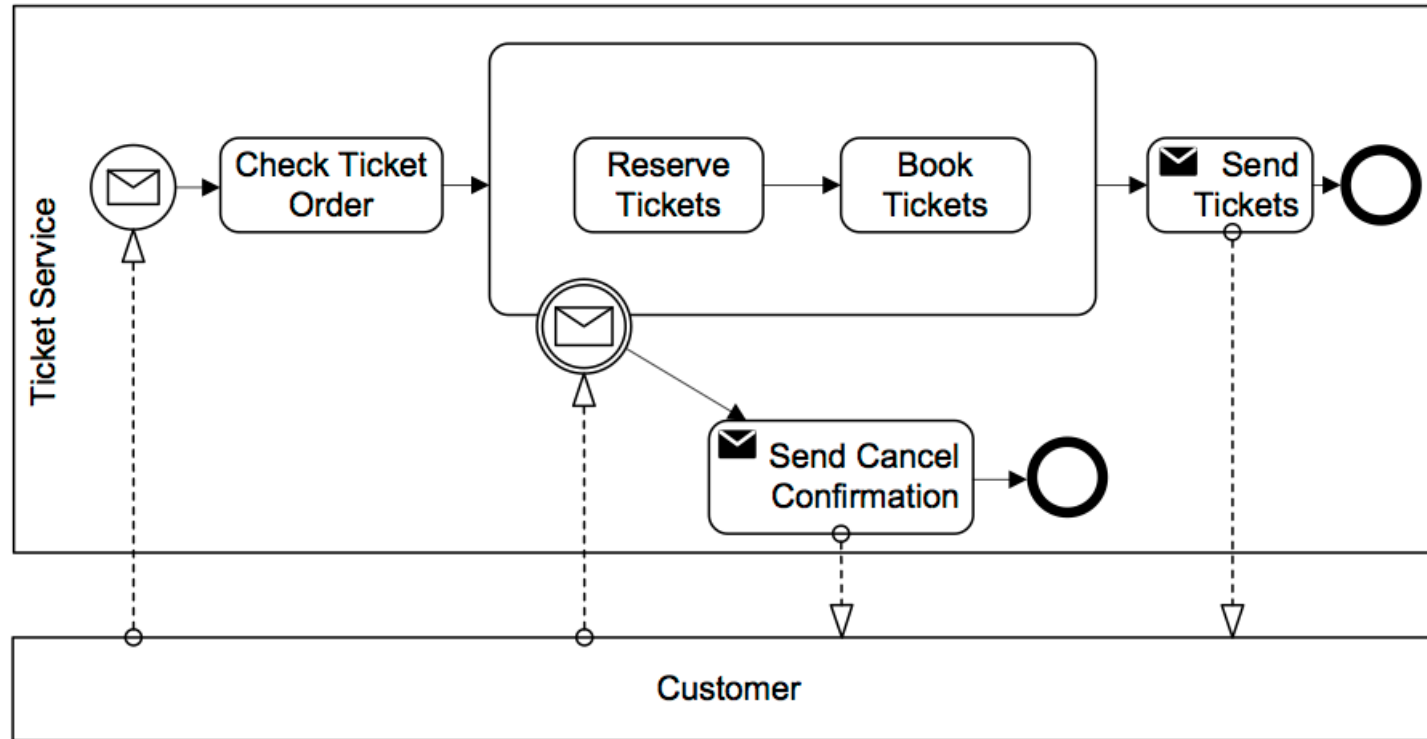

M. Weske: Business Process Management,
© Springer-Verlag Berlin Heidelberg 2012, 2007

BP with non-interrupting boundary event

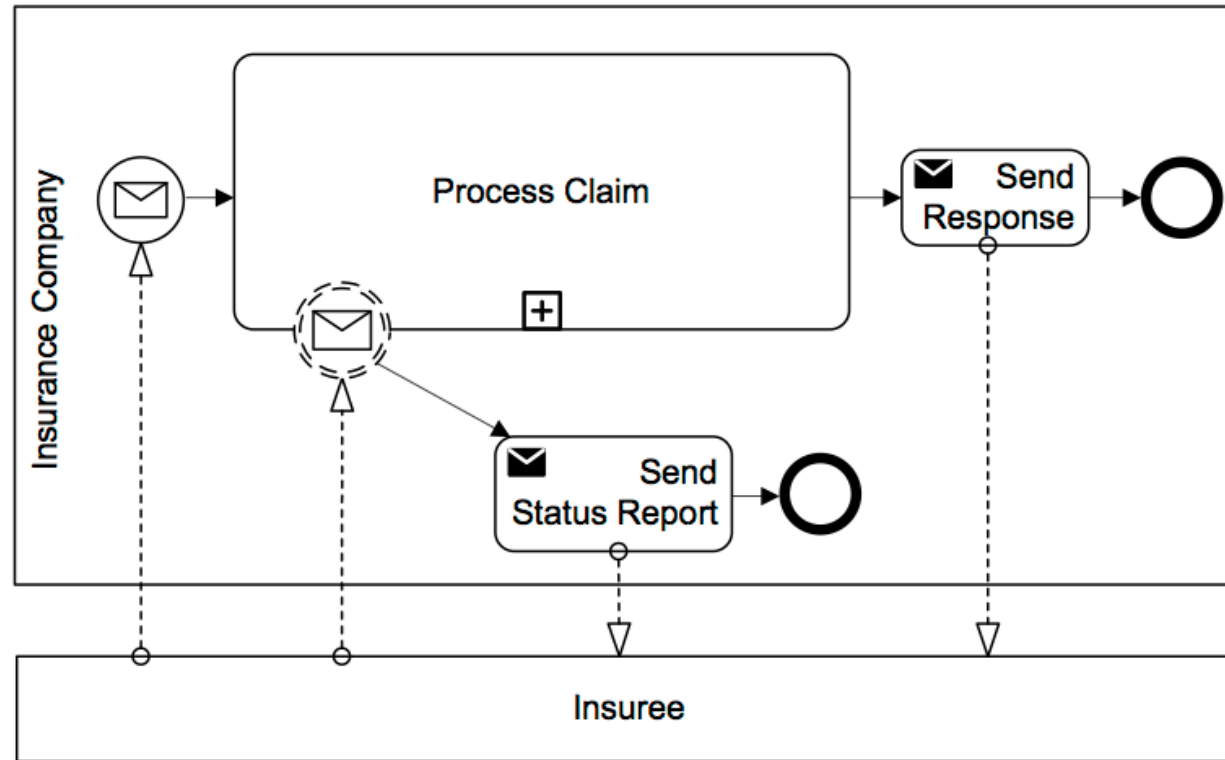

M. Weske: Business Process Management,
© Springer-Verlag Berlin Heidelberg 2012, 2007

Interrupting and non interrupting boundary time

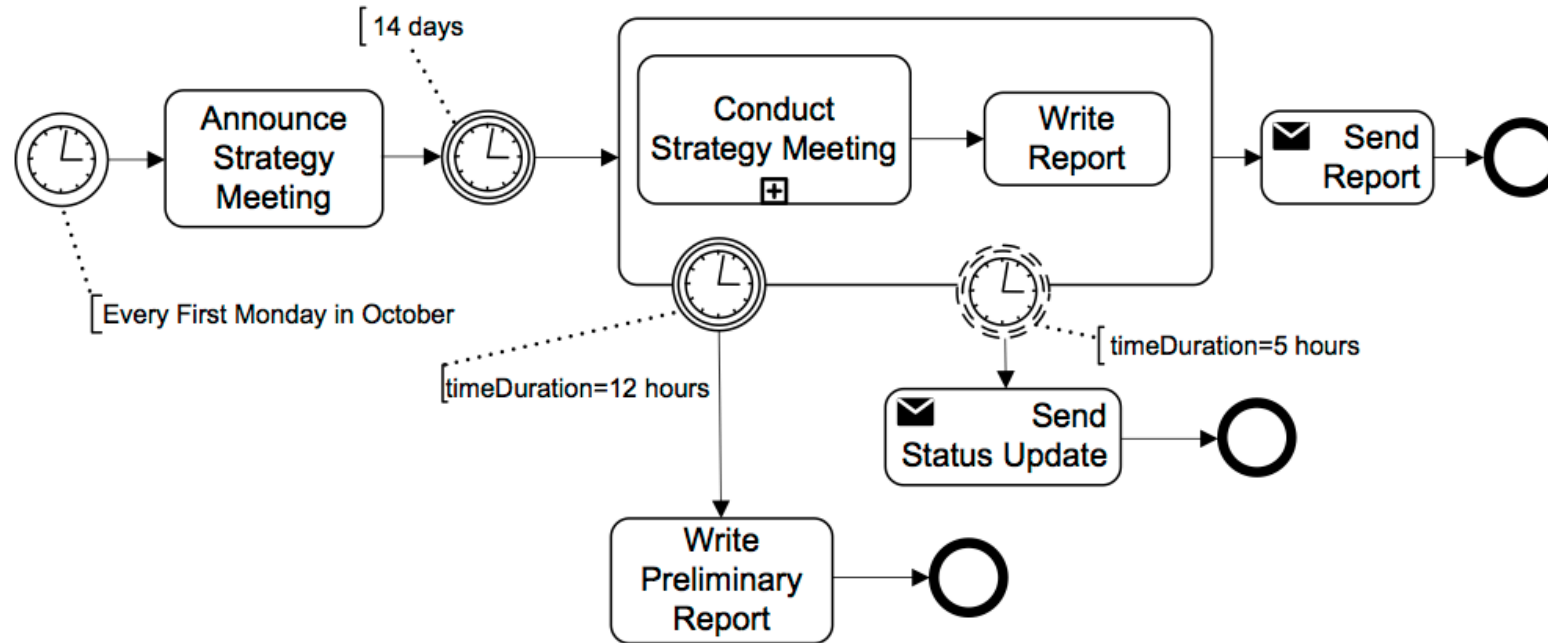

M. Weske: Business Process Management,
© Springer-Verlag Berlin Heidelberg 2012, 2007

Process Abortion

- The simplest way of handling an exception is to abort the running process and signal an improper process termination.
- Observe that if a terminate event is triggered from within a sub-process, it will not cause the abortion of the parent process but only that of the sub-process, i.e. the terminate event is only propagated downwards in a process hierarchy.

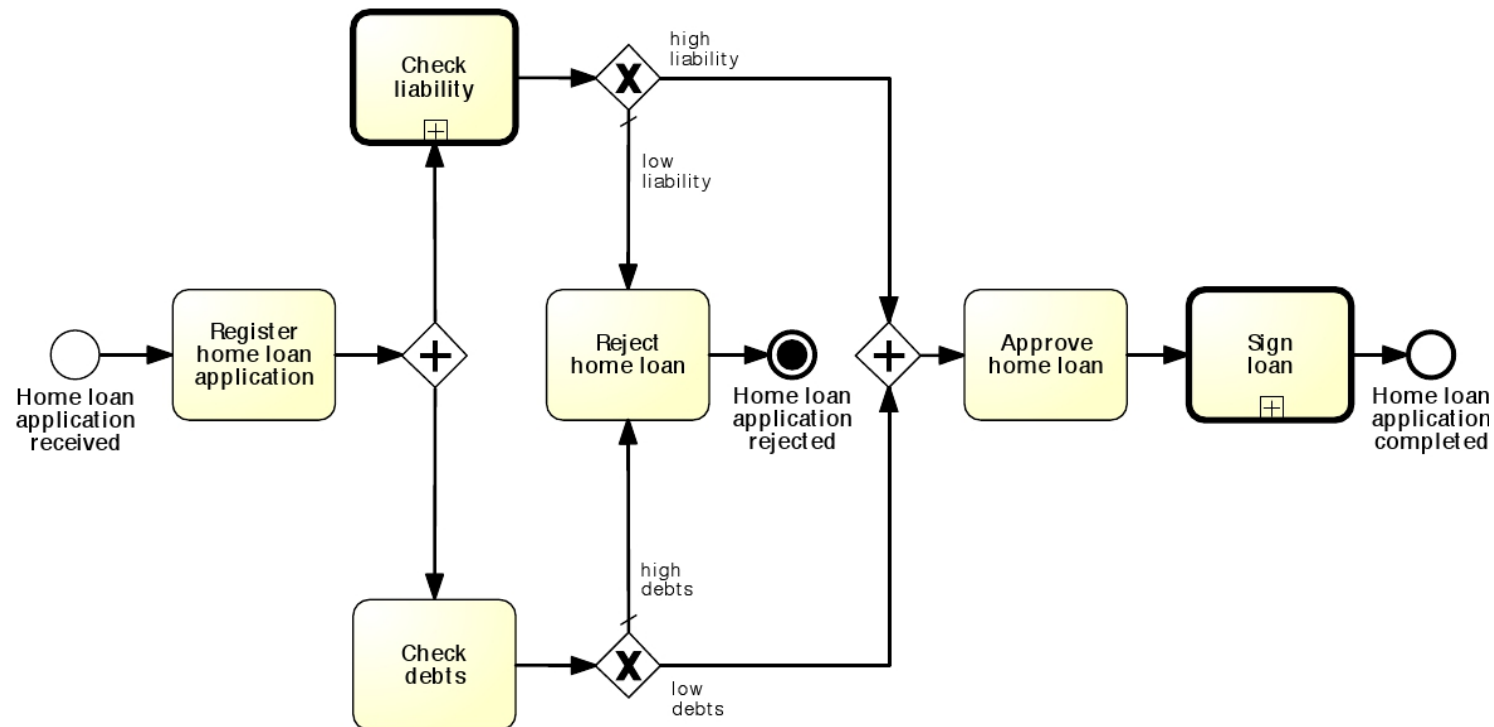

Exception (internal)

Instead of aborting the whole process, we can handle an exception by interrupting the specific activity that has caused the exception

- An end error event is used to interrupt the enclosing sub-process and throw an exception
- This exception is then caught by an intermediate catching error event which is attached to the boundary of the same sub-process
- In turn, this *boundary event* triggers the recovery procedure through an outgoing branch which is called *exception flow*

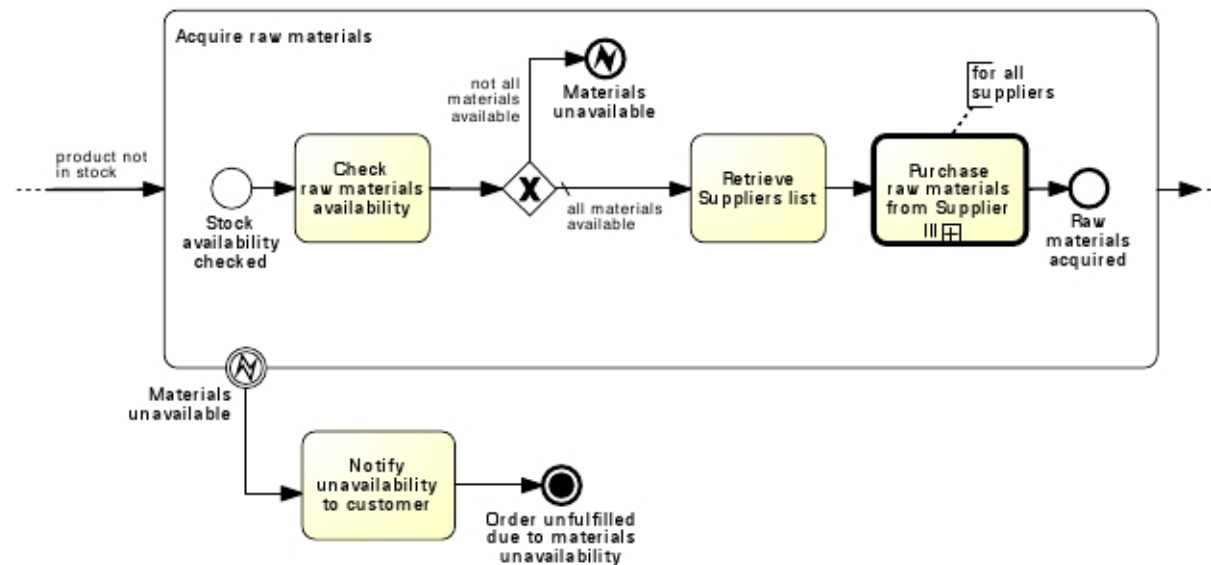

Racing Events

- A typical scenario encountered when modeling processes with events is the one where two external events *race* against one another
- The first of the two events that occurs determines the continuation of the process.

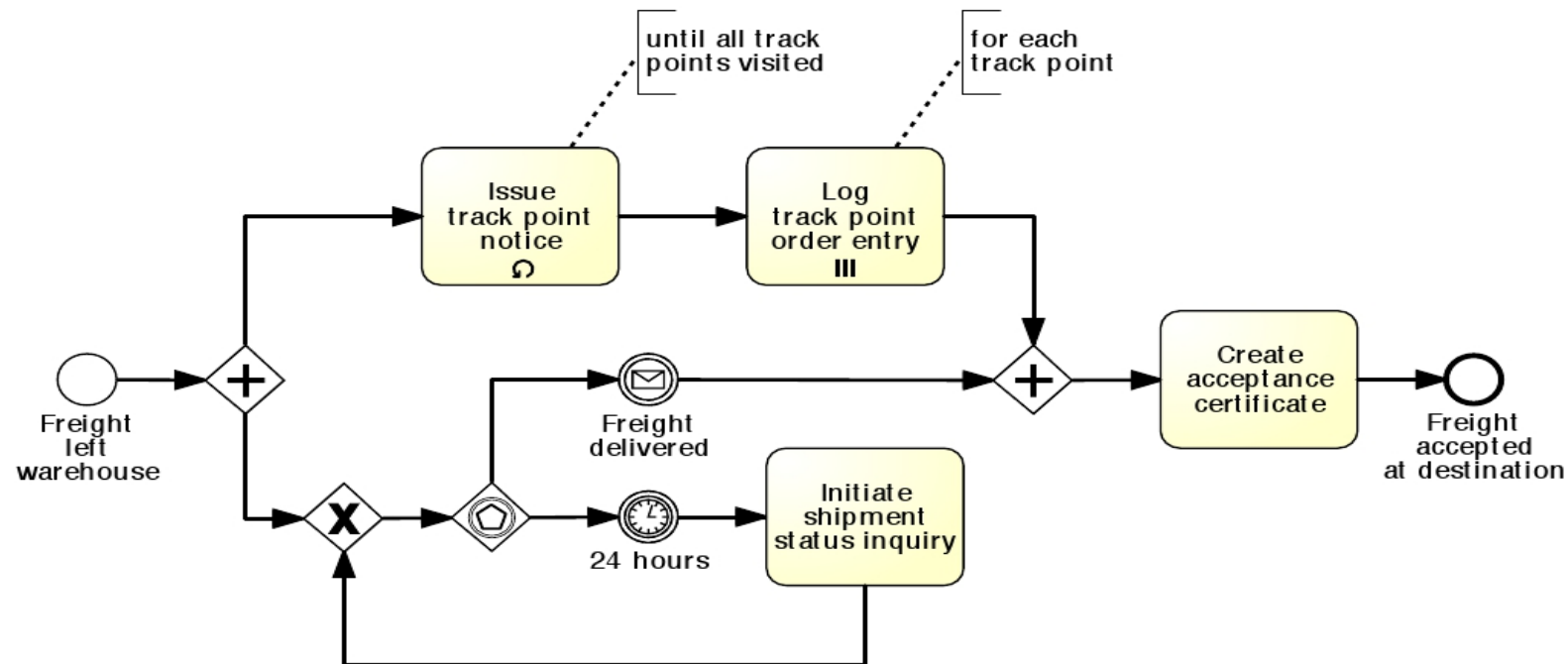

Racing Event: Event Based Gateway

- Event-based gateways can be used to avoid behavioral anomalies in the communication between pools.

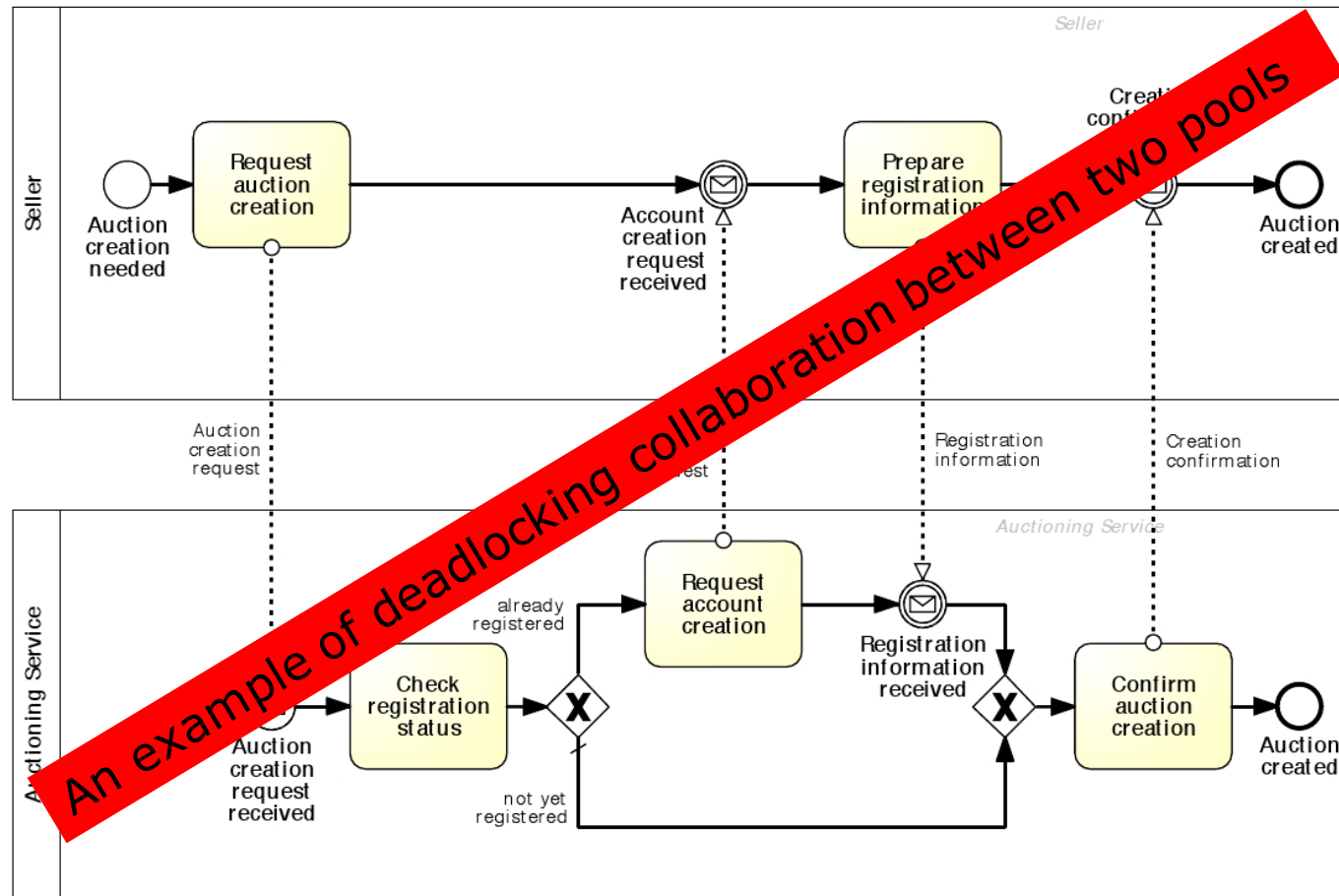

Solution

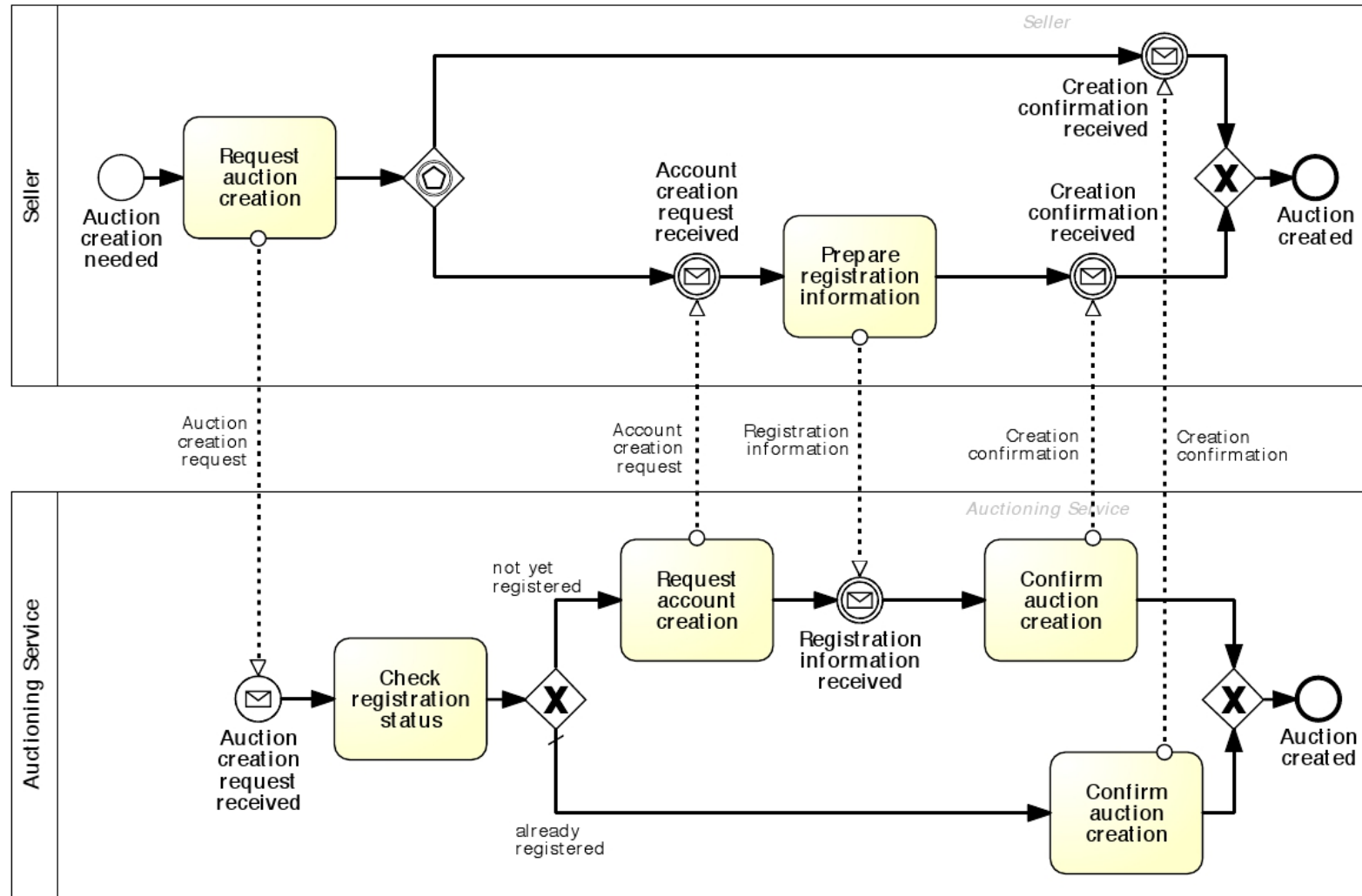

Exercise

Fix the collaboration diagram

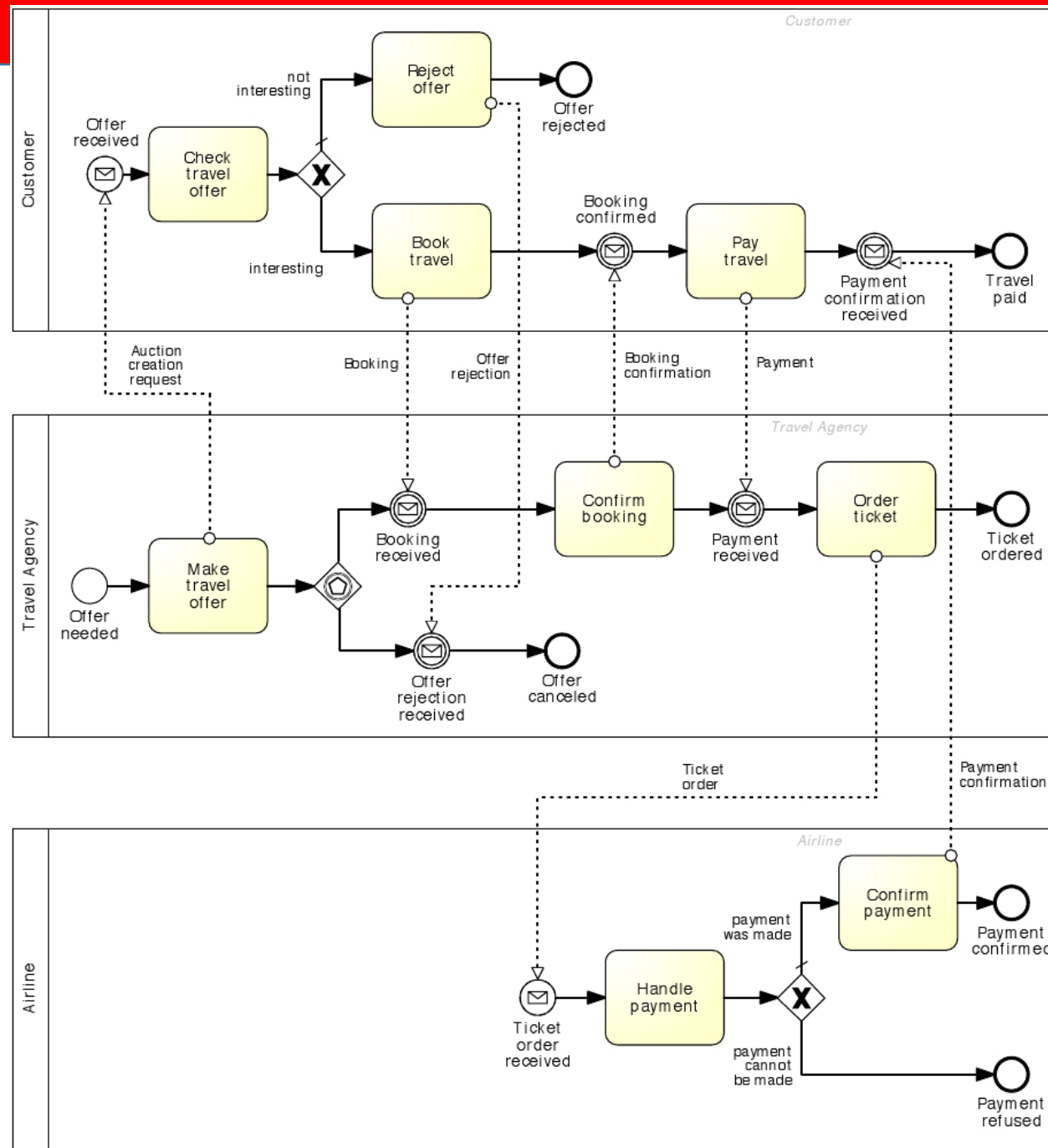

Solution

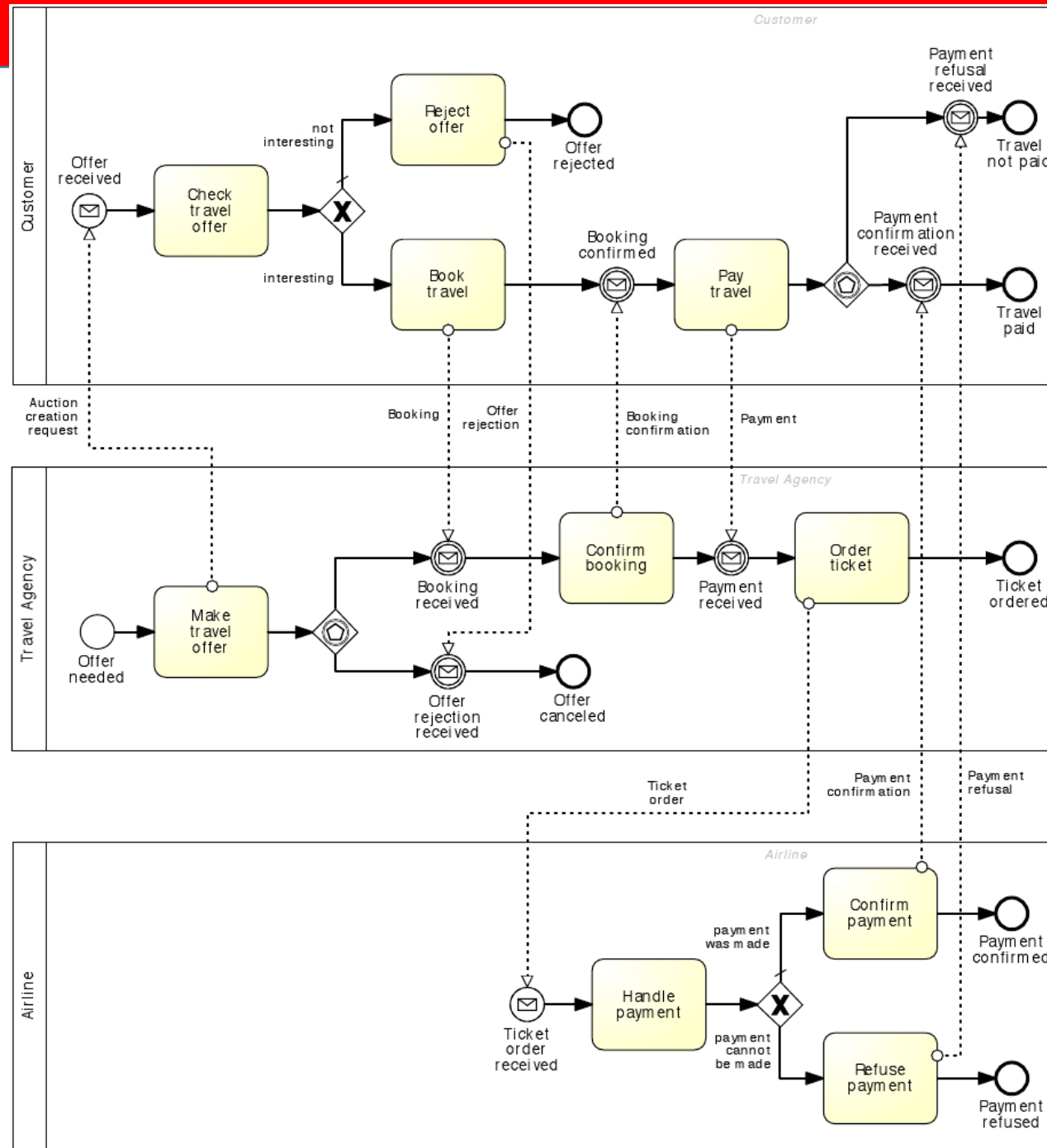

Events Combination

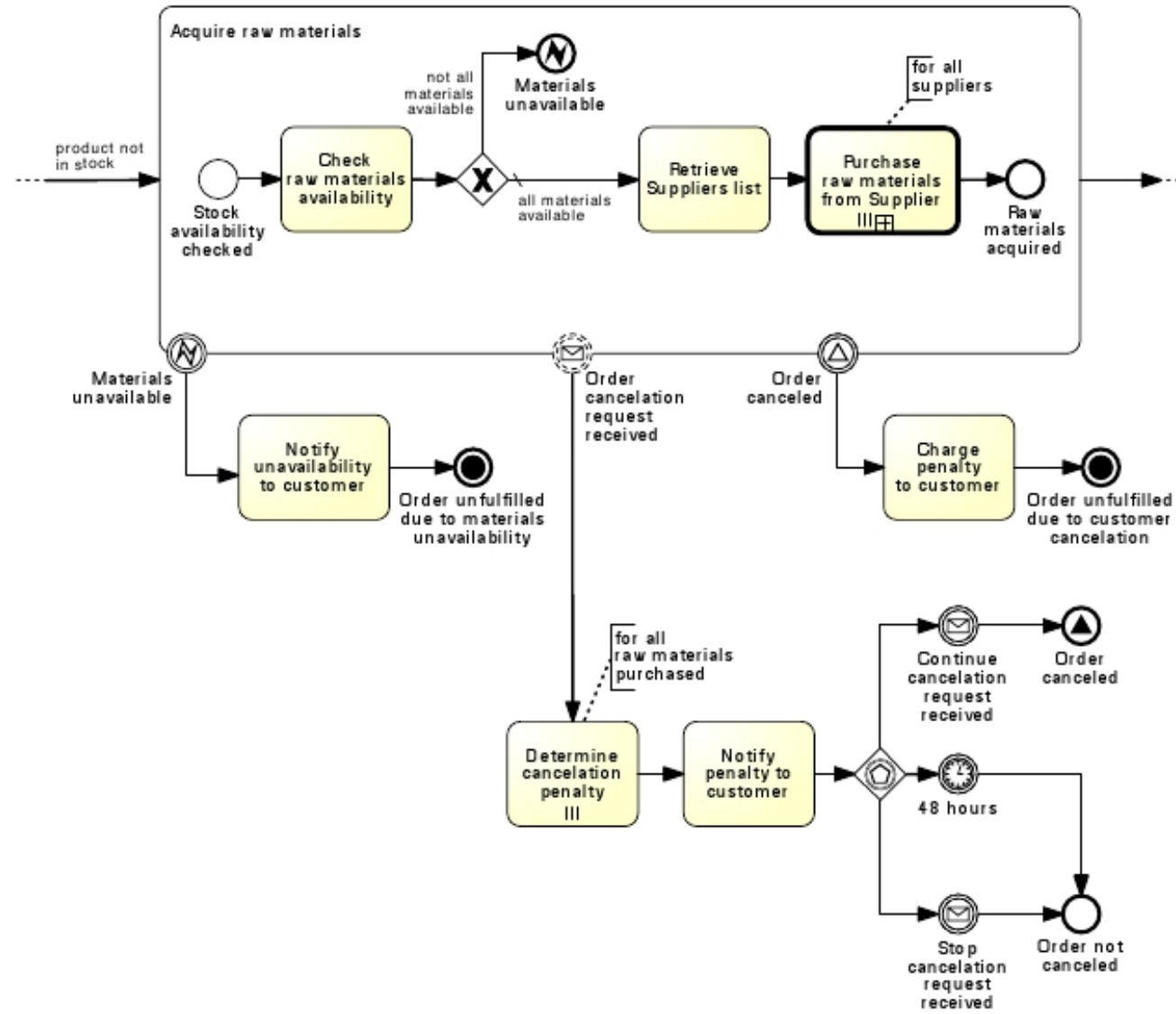

Activity Compensation

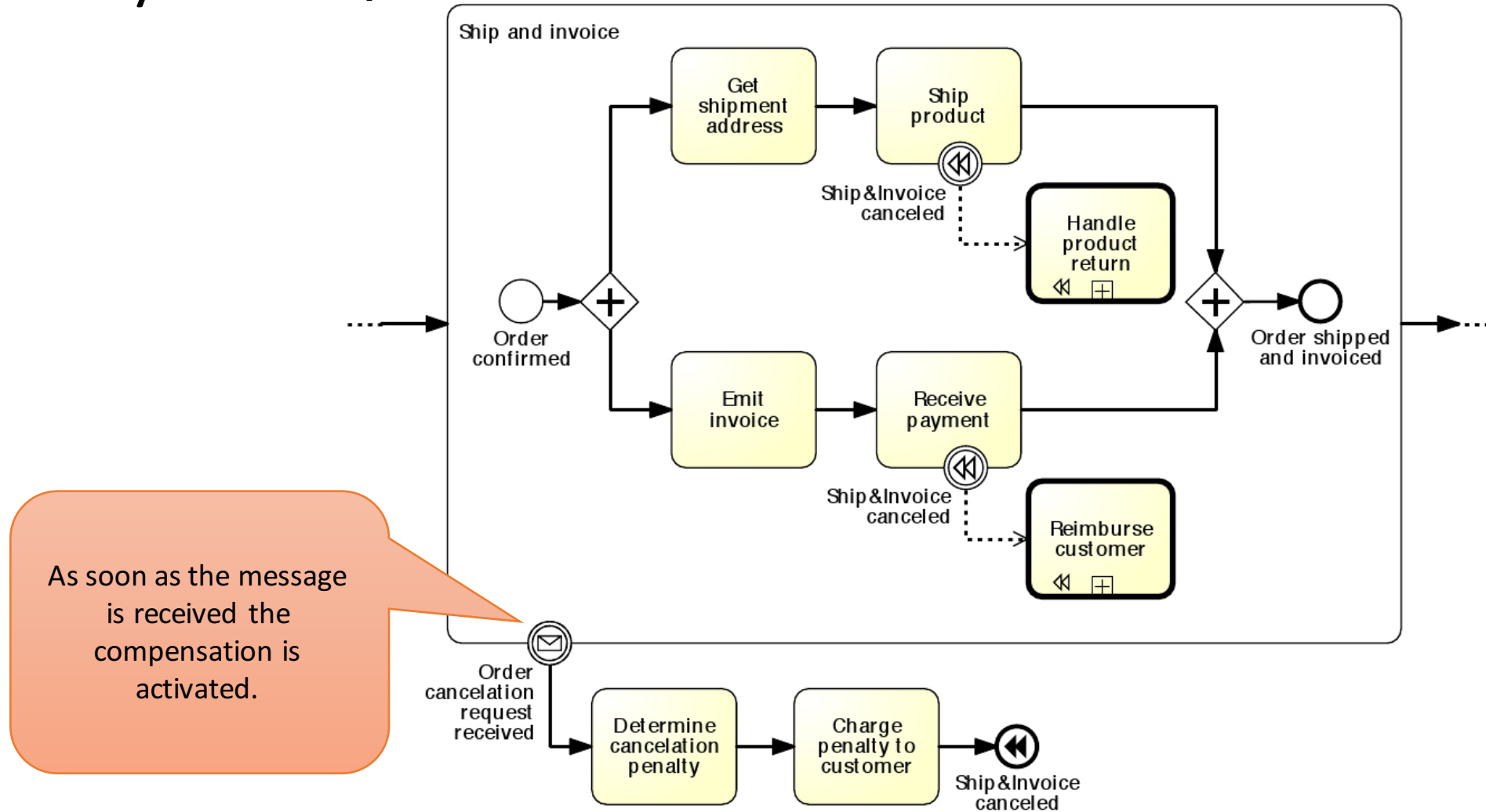

Transaction and compensation

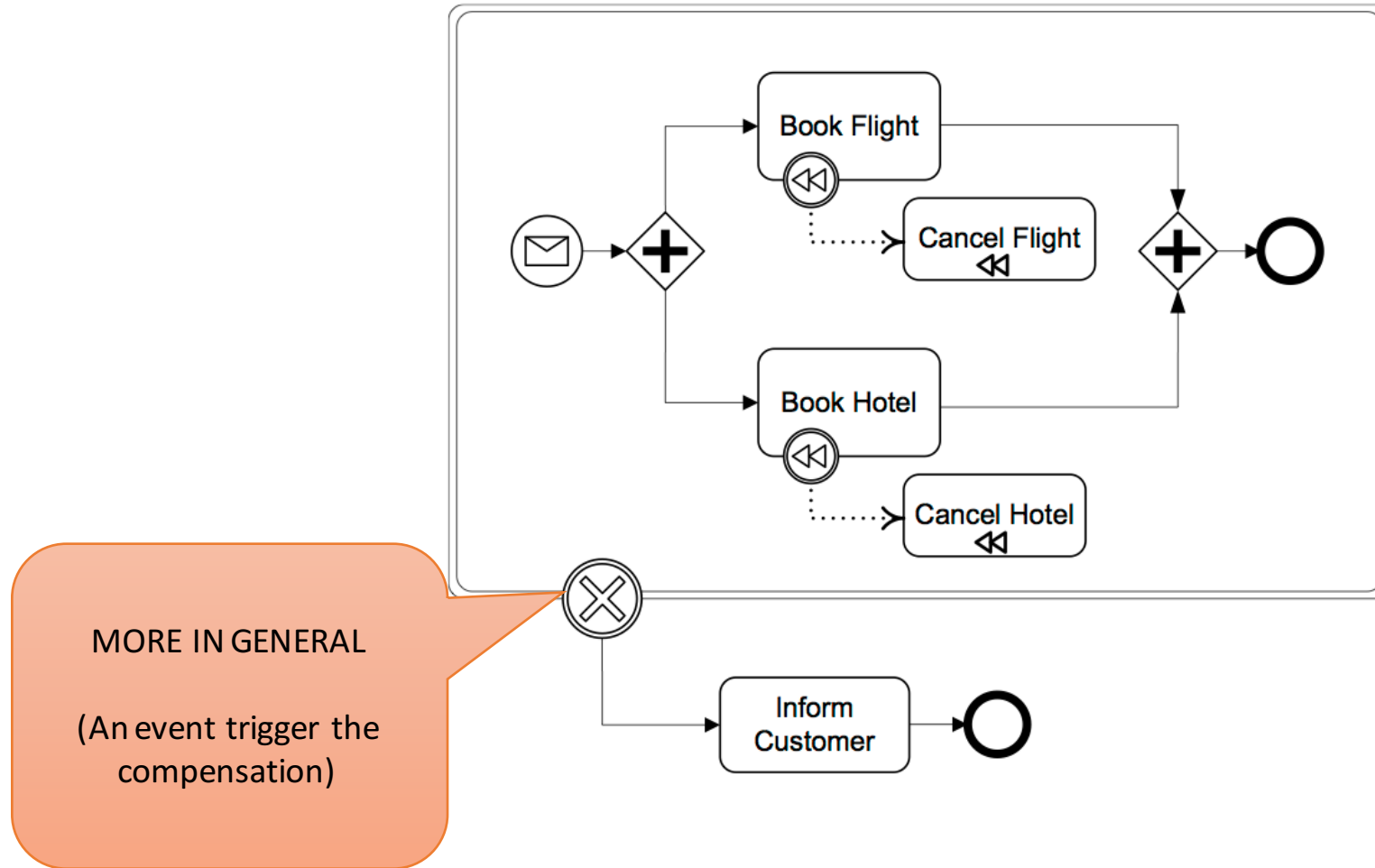

M. Weske: Business Process Management,
© Springer-Verlag Berlin Heidelberg 2012, 2007

Reccomandations

- Before adding exceptions it is important to understand the sunny-day scenario well
- Start by modeling the sunny day scenario.
- Then think of all possible situations that can go wrong.
 - For each of these exceptions, identify what type of exception handling mechanism needs to be used
 - First, determine the cause of the exception: internal or external
 - Next, decide if aborting the process is enough, or if a recovery procedure needs to be triggered
 - Finally, evaluate whether the interrupted activity needs to be compensated as part of the recovery procedure.

Exercise - Model the following routine for logging into an Internet bank account

The routine for logging into an Internet bank account starts once the credentials entered from the user have been retrieved. First, the username is validated. If the username is not valid, the routine is interrupted and the invalid username is logged. If the username is valid, the number of password trials is set to zero. Then the password is validated. If this is not valid, the counter for the number of trials is incremented and if lower than three, the user is asked to enter the password again, this time together with a CAPTCHA test to increase the security level. If the number of failed attempts reaches three times, the routine is interrupted and the account is frozen. Moreover, the username and password validation may be interrupted should the validation server not be available. Similarly, the server to test the CAPTCHA may not be available at the time of log in. In these cases, the procedure is interrupted after notifying the user to try again later. At any time during the log in routine, the customer may close the web-page, resulting in the interruption of the routine.

Solution

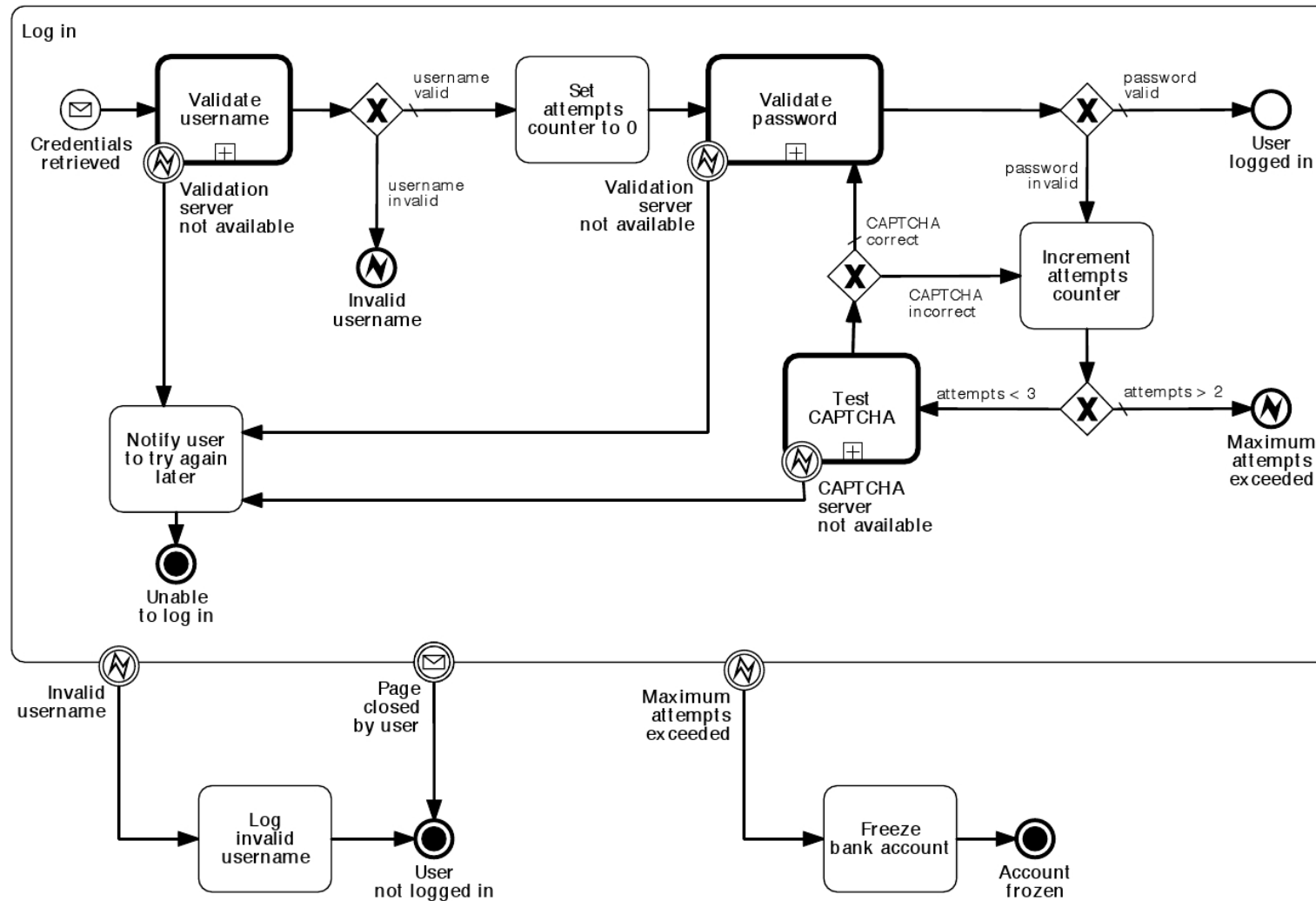

Exercise - Model the following process fragment

Once a wholesale order has been confirmed, the supplier transmits this order to the carrier for the preparation of the transportation quote. In order to prepare the quote, the carrier needs to compute the route plan (including all track points that need to be traversed during the travel) and estimate the trailer usage (e.g. whether it is a full track-load, half track-load or a single package). By contract, wholesale orders have to be dispatched within four days from the receipt of the order. This implies that transportation quotes have to be prepared within 48 hours from the receipt of the order to remain within the terms of the contract.

Solution

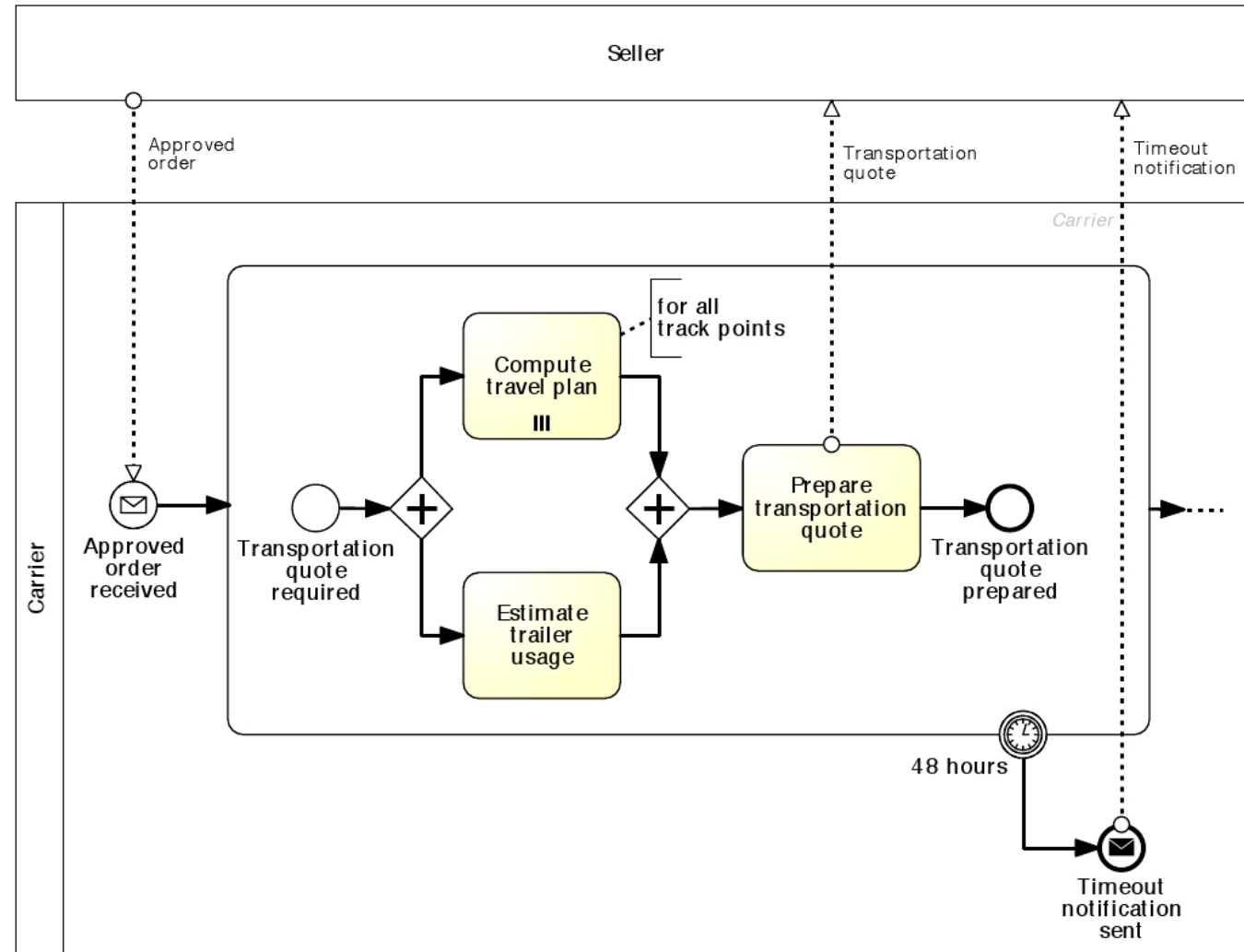

Link Events

Start Intermediate End



Intermediate Link Event – Indicates that the process flow is resumed from a previous diagram (represented elsewhere), or that it continues in a subsequent diagram (represented elsewhere). Often used as an off-page connector.

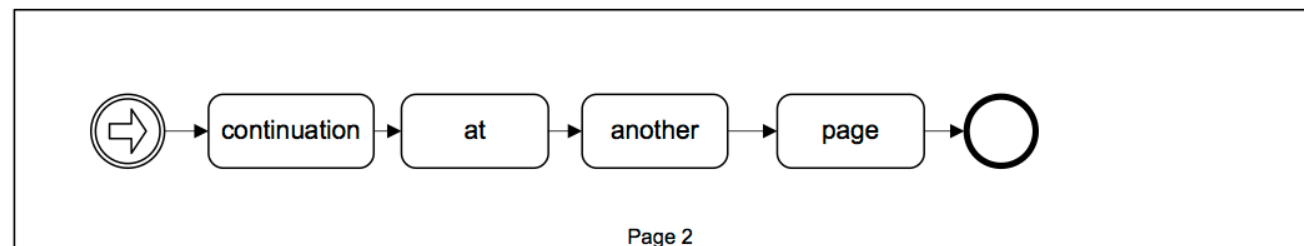
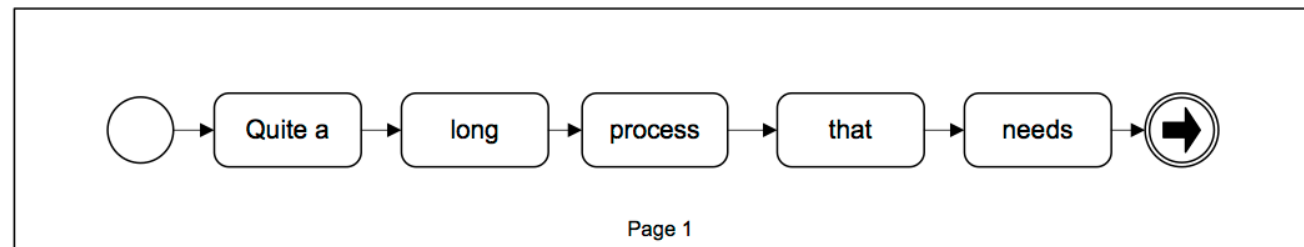

Processes and Business Rules

- A business rule implements an organizational policy or practice.
 - For example, in an online shop, platinum customers have a 20 % discount for each purchase above €250.
- Business rules can appear in different forms in a process model.
 - They can be modeled
 - in a decision activity
 - in the condition of a flow coming out of an (X)OR-split
 - **A third option is to use a dedicated BPMN event called *conditional event***

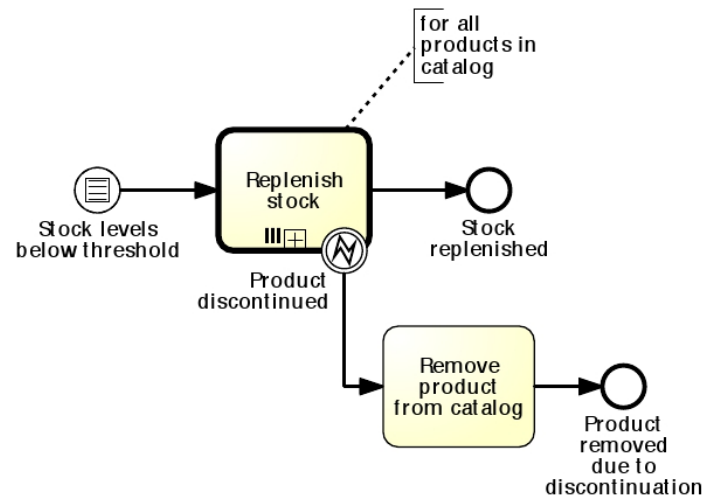

Exercise - Model the following business process snippet

In a stock exchange, stock price variations are continuously monitored during the day. A day starts when the opening bell rings and concludes when the closing bell rings. Between the two bells, every time the stock price changes by more than 10 %, the entity of the change is first determined. Next, if the change is high, a “high stock price” alert is sent, otherwise a “low stock price” alert is sent.

Solution

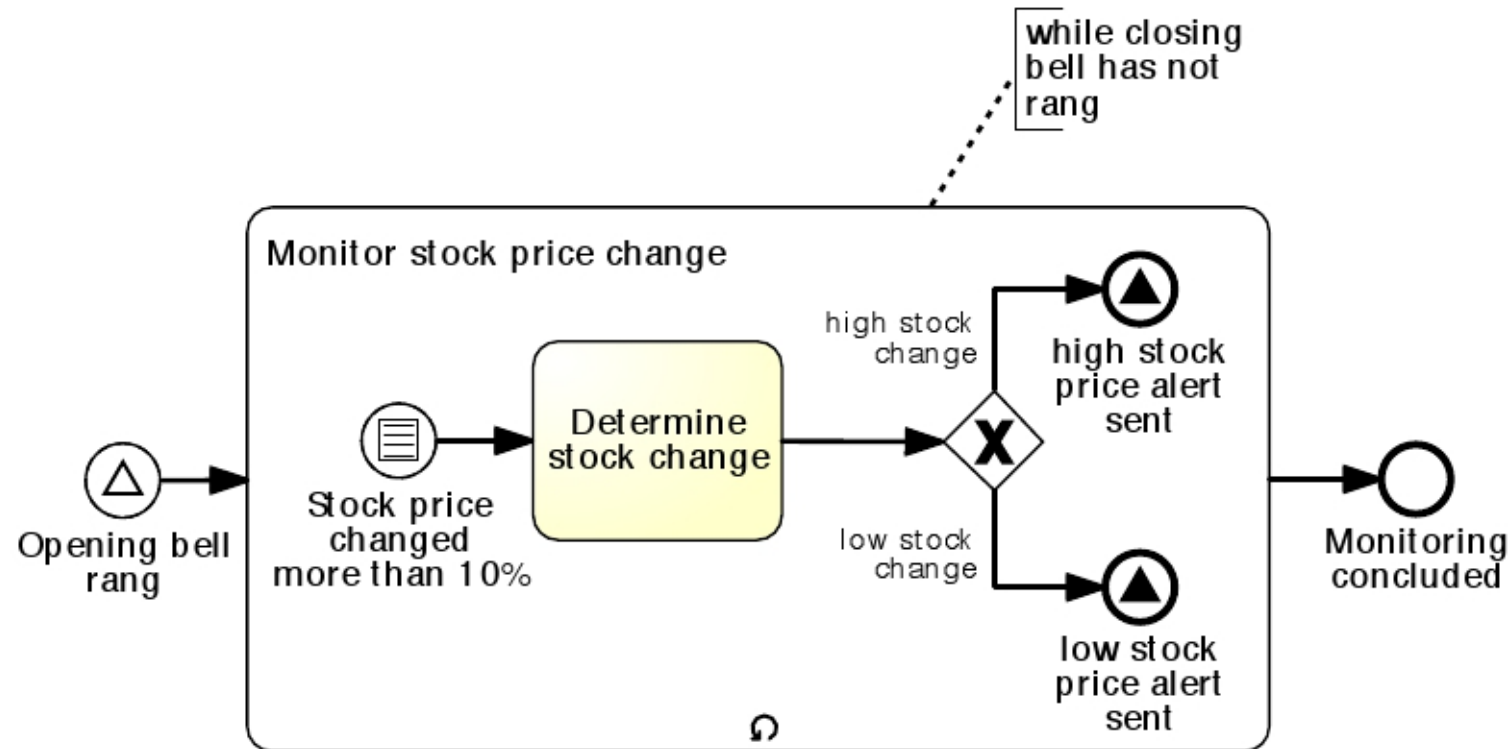

Multiple alternative start events

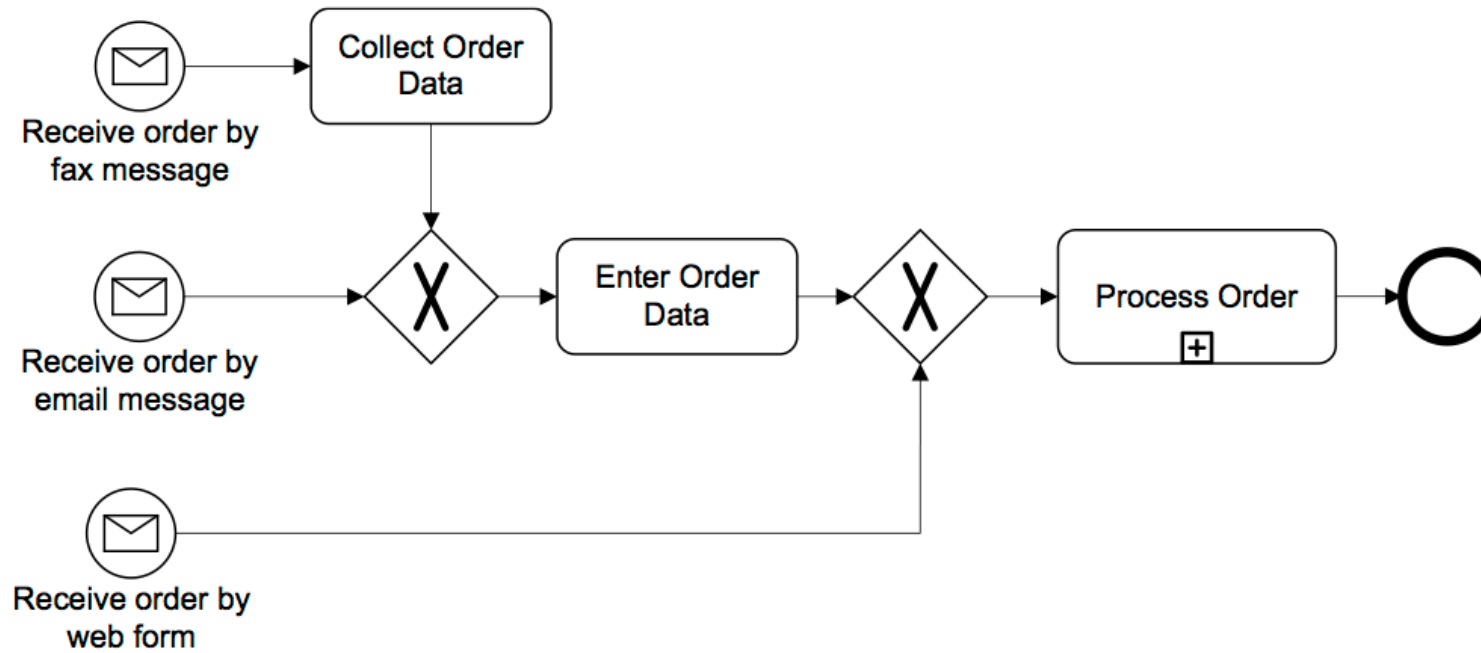

M. Weske: Business Process Management,
© Springer-Verlag Berlin Heidelberg 2012, 2007

Multiple Start Events

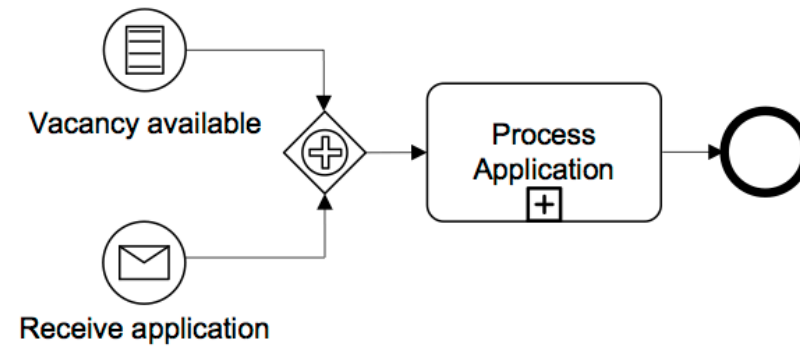

Both need to occur to instantiate the process

Information Artifacts

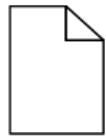

Data Object

- **Data Objects** are a mechanism to show how data is required or produced by activities. Represent input and output of a process activity



Data Object Collection

- **A Collection Data Object** represents a collection of information, e.g., a list of order items

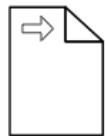

Data Input

- **A Data Input** is an external input for the entire process. A kind of input parameter

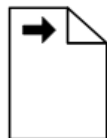

Data Output

- **A Data Output** is data result of the entire process. A kind of output parameter



Data Object in state s

Do data objects affect the token flow?

- Input data objects are required for an activity to be executed.
- Even if a token is available on the incoming arc of that activity, the latter cannot be executed until all input data objects are also available.
- A data object is available if it has been created as a result of completing a preceding activity (whose output was the data object itself), or because it is an input to the whole process (like Purchase order).
- Output data objects only affect the token flow indirectly, i.e. when they are used by subsequent activities.

Process diagram involving data-object

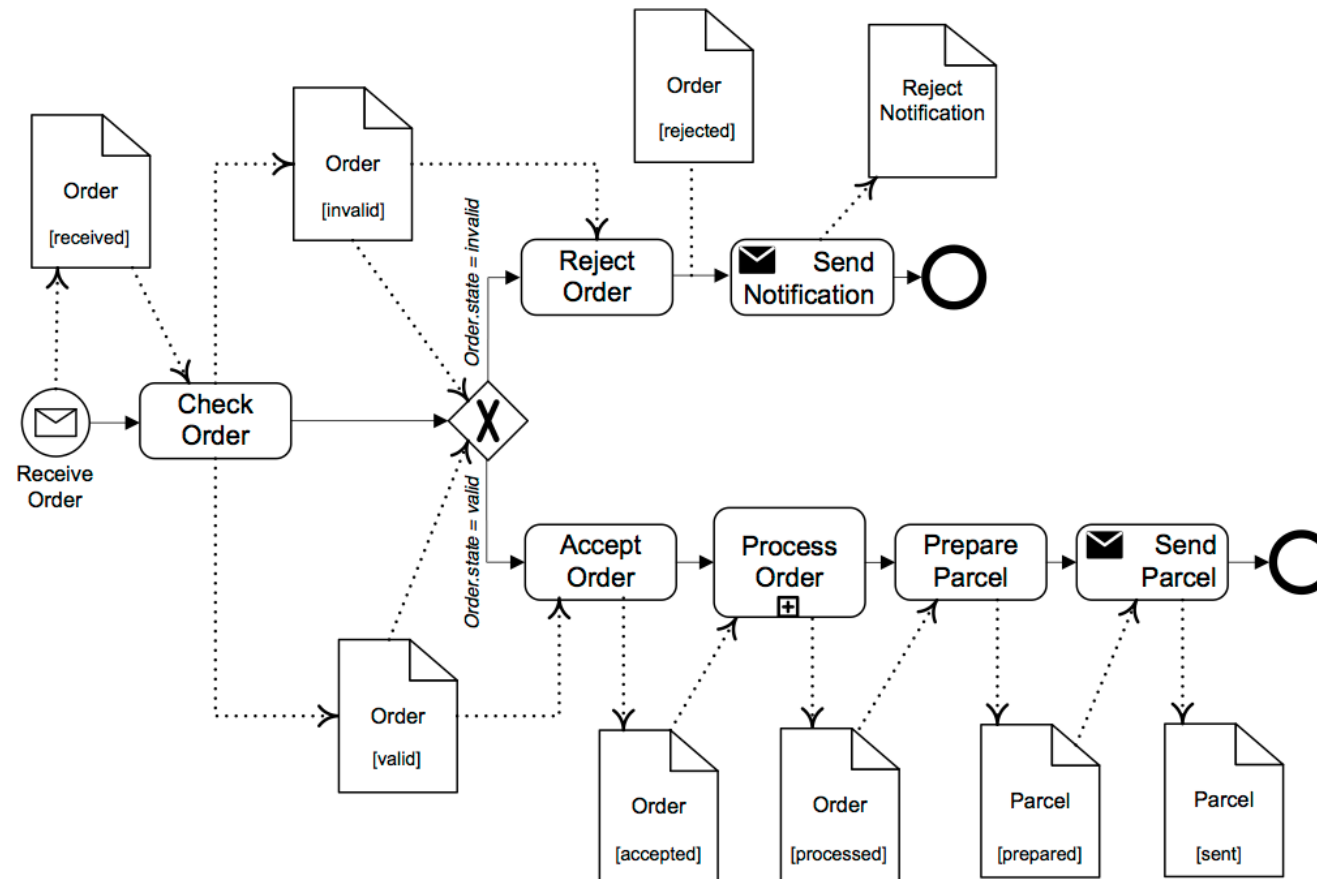

M. Weske: Business Process Management,
© Springer-Verlag Berlin Heidelberg 2012, 2007

Data Store



- ▶ **A Data Store** is a place where the process can read or write data, e.g., a database or a filing cabinet. It persists beyond the lifetime of the process instance

Process Diagram Involving Information Artifact

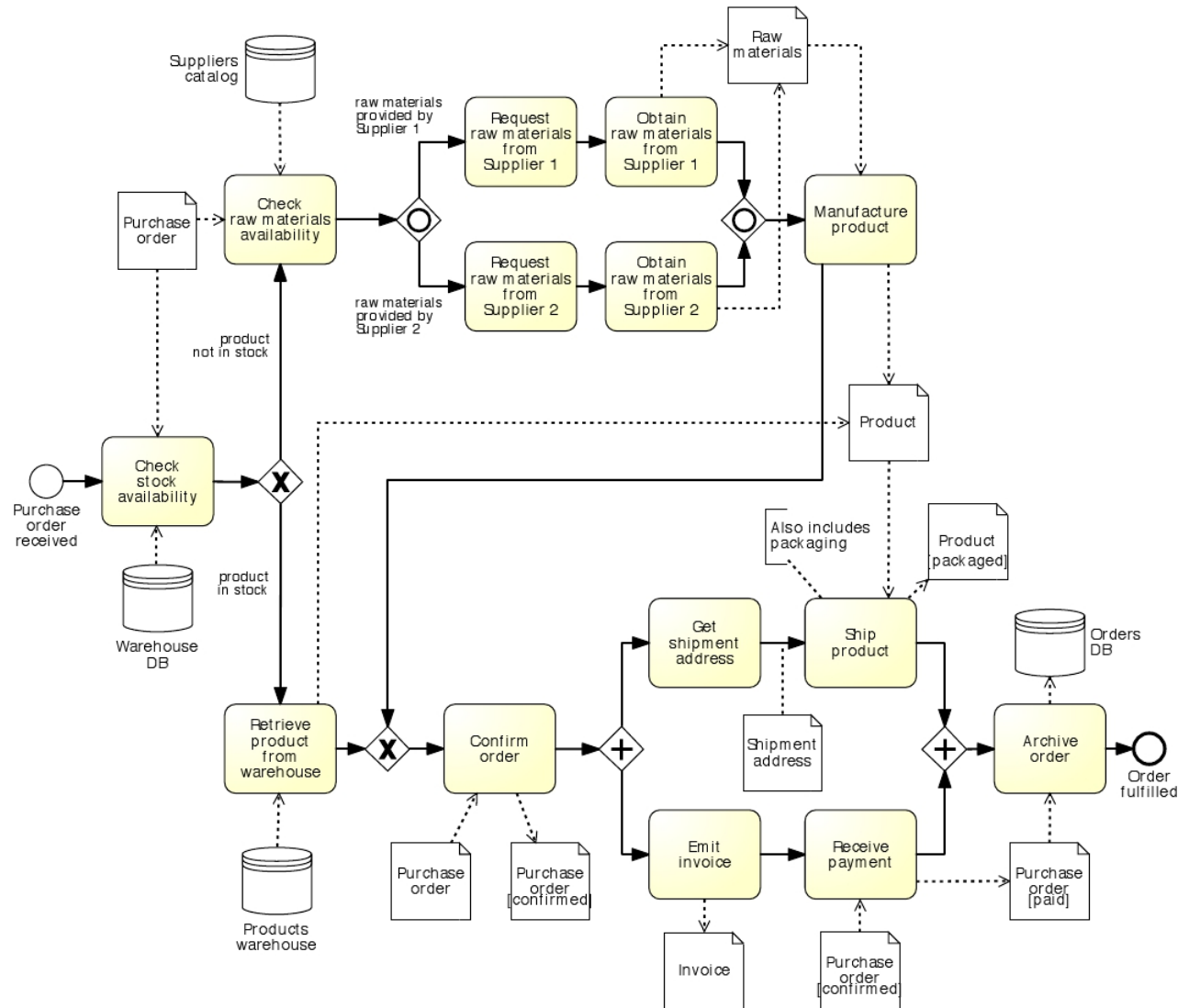

Do we always need to model data objects?

- Data objects help the reader understand the flow of business data from one activity to the other
- **However**, the price to pay is an increased complexity of the diagram
- **Use them only when they are needed for a specific purpose**, e.g. to highlight potential issues in the process under analysis or for automation

Use of BPMN elements into practice

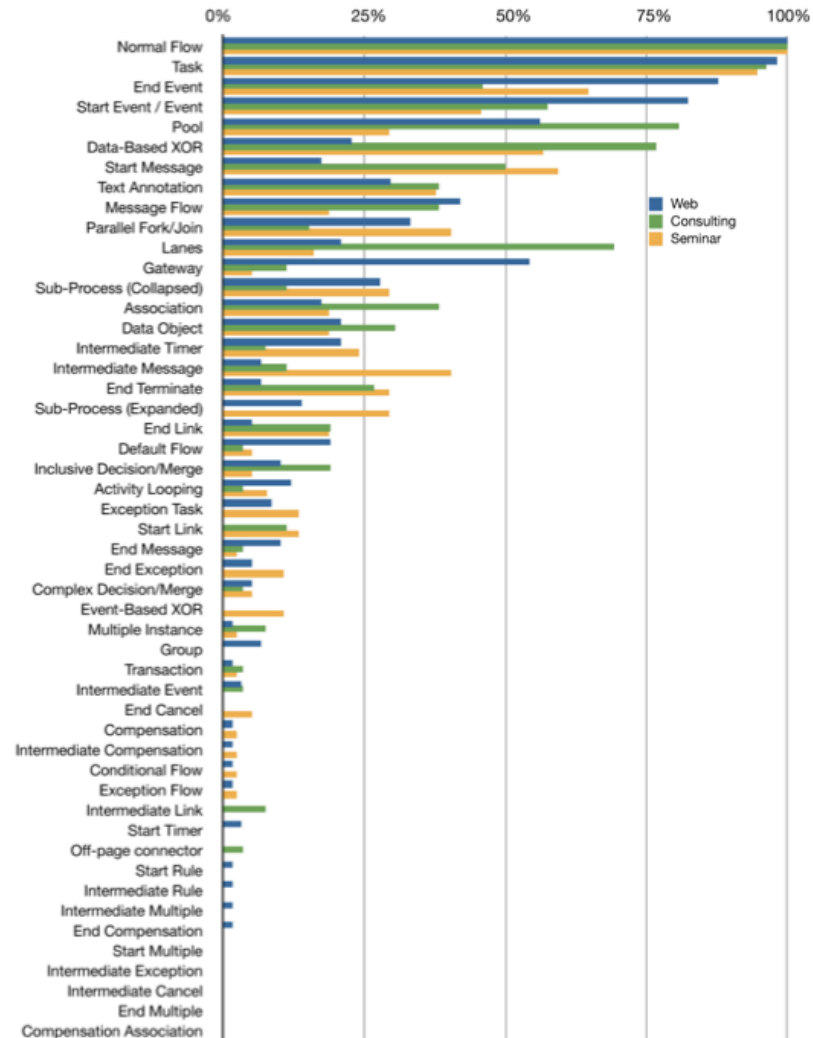

The BPMN 2.0 [15] defines 50 constructs and their attributes. However, less than 20% of its vocabulary is used regularly in designing BP models [14].

zur Muehlen, Michael and Recker, Jan C. (2008) How Much Language is Enough? Theoretical and Practical Use of the Business Process Modeling Notation . In Proceedings 20th International Conference on Advanced Information Systems Engineering, Montpellier, France.

How much language do you need?

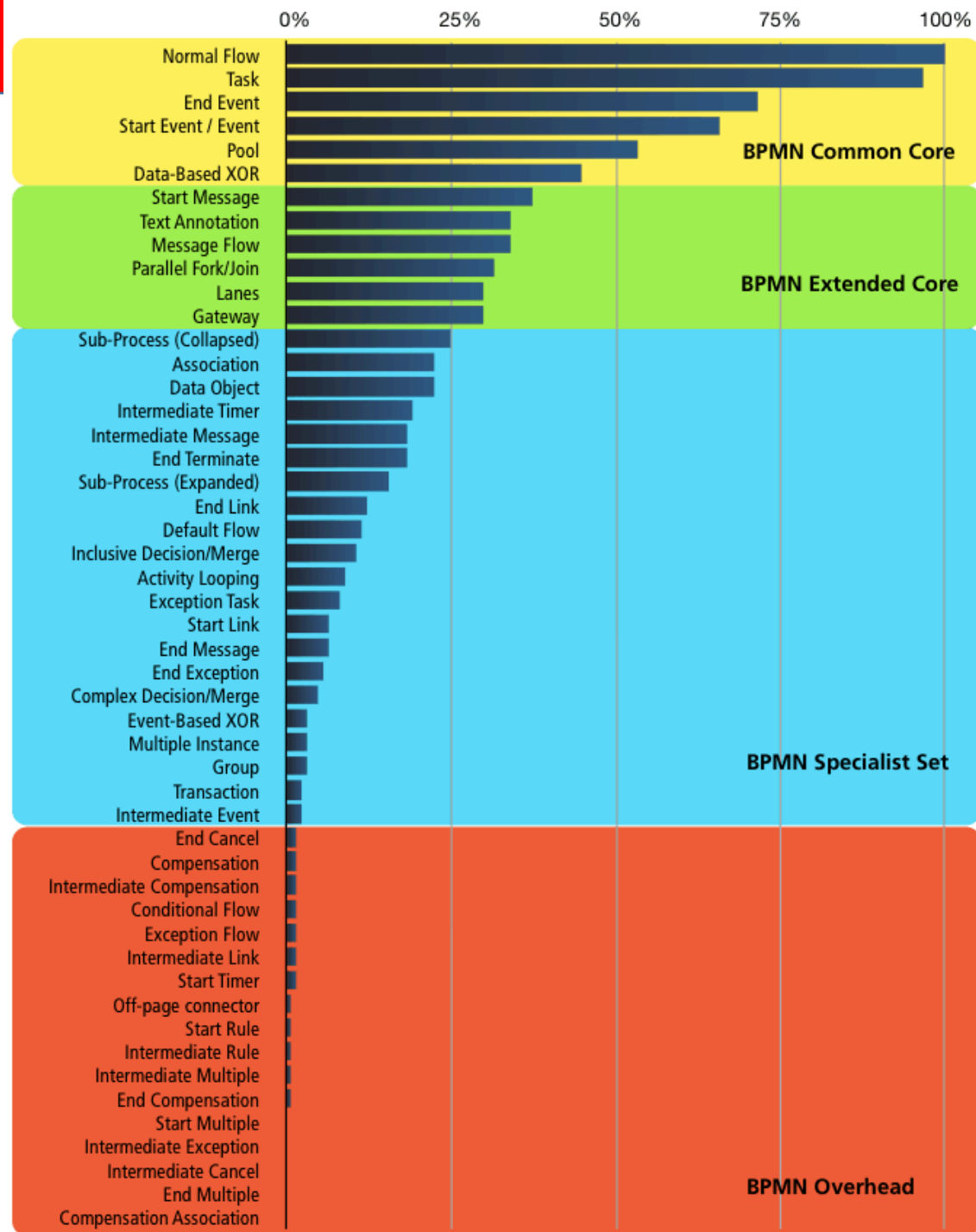

BPMN 2.0 free editors

- ADOxx - <http://www.adoxx.org/live/home>
- Oryx online editor: <http://bpt.hpi.uni-potsdam.de/Oryx>
- BizAgi editor (Windows): <http://www.bizagi.com/>
- Sketchpad Java editor (still in development): <http://sourceforge.net/projects/sketchpadbpmn/develop>
- Intalio | BPM community edition: <http://www.intalio.com/products/bpm/community-edition/>
- Eclipse BPMN modeler: <http://www.eclipse.org/bpmn/>
- Visio stencils: <http://bpt.hpi.uni-potsdam.de/Public/BPMNCorner#Tooling>
- Other tools & info: http://bpmn.org/BPMN_Supporters.htm

Modeling Environment

- <http://academic.signavio.com/p/register?link=49b6ca940da04308ac5f133740119d41>



Personal _____

First Name	Last Name
University email	

Password _____

Use a random password with at least 6 characters.

Password	Confirm Password
----------	------------------

Language _____

Country	▼
Language	English ▼

Academic workspace for
University of Camerino - Dr. Barbara Re

Registration for the Signavio BPM Academic Initiative

Please confirm the invitation to the University of Camerino workspace from Dr. Barbara Re by filling in the form.

Right after that you can start modeling collaboratively with your colleagues in the secure workspace.

Are you already registered? Then please go to the login form directly.



Business Process (Modelling Activities)

Execises

Using a BPMN 2.0 notation model the following process

- Cooking's Apple Pie
- Enrollment at university
- Buy a fly ticket
- Buy a book on-line
- Moving from one city to another

Let's Modelling: Insurance Claim

1. **recording** the receipt of the claim
2. establishing the **type** of the claim
3. checking covering of client's **policy**
4. checking the **premium** (payments up to date?)
5. **rejection**, if 3 or 4 has negative result
6. producing a **rejection letter**
7. roughly **estimate** the amount to be paid, if 3 & 4 have positive results 8.
appointment of an **assessor**, if needed
9. **revision** of the amount offered to the client
10. recording client's **reaction**
11. **assessment** of objection: decision to revise 9 or take legal action 12 12.
legal proceedings
13. **payment** of claim
14. **filing** and closure of claim

Modelling Travel agency

Travel agency: define a series of task for booking a flight, a hotel and optionally a car, with the possibility to change dates, to cancel the booking, to confirm the booking. Then, draw a process diagram relating the tasks.



Modelling Coffee break

Coffee break: draw the process diagram for a vending machine that accepts a coin, then gives the possibility (1) to get a coffee or (2) to insert another coin and get either a cappuccino or a tea. Draw the process diagrams for a compatible and a "problematic" butler robot.



Modelling Bike Sharing and Bike Travel

Bike Sharing and Bike Travel: define a series of task for bike traveling, with the possibility to register, to track, and to maintain the bike. Then, draw a process diagram relating the tasks.



BPMN by example





Object Management Group Business Process Model and Notation



Home	Documents	Quick Guide	Examples	Implementers	Resources	Cloud Apps
----------------------	---------------------------	-----------------------------	--------------------------	------------------------------	---------------------------	----------------------------

Charter

A standard Business Process Model and Notation (BPMN) will provide businesses with the capability of understanding their internal business procedures in a graphical notation and will give organizations the ability to communicate these procedures in a standard manner. Furthermore, the graphical notation will facilitate the understanding of the performance collaborations and business transactions between the organizations. This will ensure that businesses will understand themselves and participants in their business and will enable organizations to adjust to new internal and B2B business circumstances quickly.

 **BPM GLOSSARY** 
Search for a BPM term:

[Submit](#)

Current BPMN Specification

- [BPMN v2.0](#)
- [BPMN 2.0 by Example: non-normative OMG document with BPMN 2.0 examples](#)
- [BPMN Quick Guide](#)

BPM Certification



The [OCEB program](#) consists of five examinations, granting five Certifications. Above the single Fundamental level, the program splits into two tracks - one Business-oriented , the other Technically oriented.



Questions?